

SPLIT

NEW

Compact Cassette

4-way Flow

Compact & Comfort



Compact and stylish panel design

Compact and stylish panel design fits the grid type ceiling. It is a linear design suitable for grid shape of 620 mm × 620 mm grid ceiling.

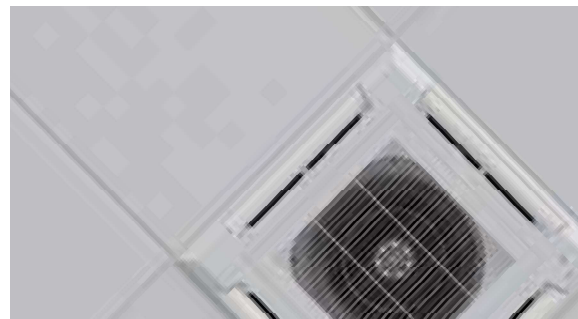

Easy maintenance

Maintenance is easier by removing the ceiling panel next to the grill, maintenance can be done, and new installation of inspection hole is unnecessary, so construction costs can be suppressed.

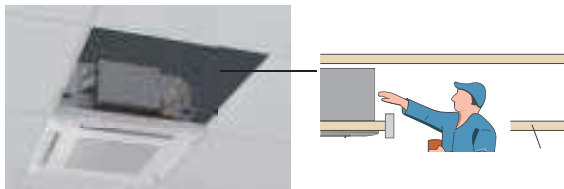

The air inlet grill can be installed in various directions, so maintenance is easy.



Flexible installation

It is suitable for ceiling of grid type and it has high degree of freedom of installation and it can be installed beside lighting and ventilation opening.



Low ambient operation

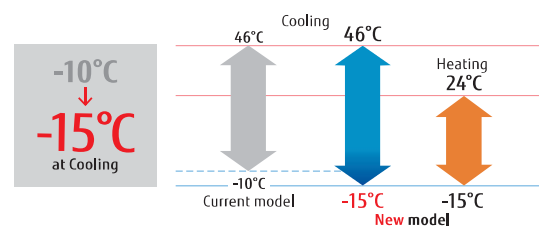



Model: AUXG09KVLA / AUXG12KVLA / AUXG14KVLA / AUXG18KVLA / AUXG22KVLA / AUXG24KVLA



For AUXG9/12/14KVLA

For AUXG18/22KVLA

For AUXG24KVLA

Specifications

Model No.	Indoor unit		AUXG09KVLA	AUXG12KVLA	AUXG14KVLA	AUXG18KVLA	AUXG22KVLA	AUXG24KVLA
	Outdoor unit		AOYG09KBTB	AOYG12KBTB	AOYG14KBTB	AOYG18KBTB	AOYG22KBTB	AOYG24KBTB
Power Source			Single-phase, ~230V, 50Hz					
Capacity	Cooling	kW	2.5 (0.9-3.2)	3.5 (0.9-4.4)	4.3 (0.9-5.4)	5.2 (0.9-5.9)	6.0 (0.9-6.7)	6.8 (0.9-8.0)
	Heating		3.2 (0.9-4.7)	4.1 (0.9-5.7)	5.0 (0.9-6.5)	6.0 (0.9-7.5)	7.0 (0.9-8.0)	7.5 (0.9-9.1)
Input Power	Cooling/Heating	kW	0.55/0.79	0.93/1.08	1.28/1.32	1.60/1.66	1.82/1.87	2.21/2.03
EER	Cooling	W/W	4.57	3.76	3.36	3.25	3.30	3.08
	Heating		4.05	3.80	3.79	3.61	3.74	3.69
Pdesign	Cooling/Heating(-10°C)	kW	2.5/2.6	3.5/3.4	4.3/3.8	5.2/4.4	6.0/4.8	6.8/6.0
SEER	Cooling	W/W	6.70	6.60	6.50	6.60	6.60	6.10
	Heating (Average)		4.40	4.30	4.40	4.20	4.30	4.00
Energy Efficiency Class	Cooling		A++	A++	A++	A++	A++	A++
	Heating (Average)		A+	A+	A+	A+	A+	A+
Max. Operating Current	Cooling/Heating	A	7.9	9.7	10.2	12.1	12.6	13.6
	Cooling	kWh/a	131	186	231	275	318	390
Heating	826		1,106	1,208	1,466	1,562	2,097	
Moisture Removal		l/h	0.6	1.2	1.5	2.2	2.6	2.7
Sound Pressure Level	Indoor (Cooling)	H/M/L/Q	33/31/29/27	37/34/30/27	38/34/30/27	38/34/30/26	44/42/36/30	49/44/36/30
	Indoor (Heating)	H/M/L/Q	34/32/29/27	37/34/31/29	43/38/34/30	43/38/34/30	45/43/40/33	49/45/40/33
Sound Power Level	Outdoor(Cooling/Heating)	High	46/46	47/47	49/49	50/50	51/51	53/54
	Outdoor(Cooling/Heating)	High	46/47	49/49	50/55	50/55	56/57	59/61
Airflow Rate	Indoor / Outdoor (Cooling)	High	540/1,480	600/1,580	680/1,670	680/2,160	830/2,240	930/2,700
	Indoor / Outdoor (Heating)	High	540/1,410	600/1,520	800/1,580	800/1,830	860/1,960	930/2,700
Net Dimensions H x W x D	Indoor	mm	245x570x570	245x570x570	245x570x570	245x570x570	245x570x570	245x570x570
	Outdoor	mm	542x799x290	542x799x290	542x799x290	632x799x290	632x799x290	716x820x315
Weight	Indoor	kg(lbs)	15 (33)	15 (33)	15 (33)	15 (33)	16 (35)	16 (35)
	Outdoor	kg(lbs)	32 (71)	33 (73)	33 (73)	36 (79)	38 (84)	42 (93)
Connection Pipe Diameter (Liquid / Gas)		mm	6.35/9.53	6.35/9.53	6.35/9.53	6.35/12.70	6.35/12.70	6.35/12.70
Drain hose Diameter (I.D./O.D.)		mm	25/32	25/32	25/32	25/32	25/32	25/32
Max Pipe Length (Pre-Charge)		m	20 (15)	25 (15)	25 (15)	30 (20)	30 (20)	30 (20)
Max Height Difference			15	20	20	20	25	25
Operation Range	Cooling	*CDB	-15 to 46	-15 to 46	-15 to 46	-15 to 46	-15 to 46	-15 to 46
	Heating		-15 to 24	-15 to 24	-15 to 24	-15 to 24	-15 to 24	-15 to 24
Refrigerant	Type (Global Warming Potential)		R32 (675)	R32 (675)	R32 (675)	R32 (675)	R32 (675)	R32 (675)
	Charge	kg(CO2eq-T)	0.85 (0.574)	0.85 (0.574)	0.85 (0.574)	1.02 (0.689)	1.25 (0.844)	1.25 (0.844)
Cassette Grille	Model name		UTG-UFYF-W	UTG-UFYF-W	UTG-UFYF-W	UTG-UFYF-W	UTG-UFYF-W	UTG-UFYF-W
	Dimensions (H x W x D)	mm	49x620x620	49x620x620	49x620x620	49x620x620	49x620x620	49x620x620
	Weight	kg(lbs)	2.3 (5.1)	2.3 (5.1)	2.3 (5.1)	2.3 (5.1)	2.3 (5.1)	2.3 (5.1)

Optional parts

Wireless Remote Controller: UTY-LNTY

Wired Remote Controller: UTY-RNRYZ3, UTY-RLRY, UTY-RVNYM, UTY-RNNYM

Simple Remote Controller: UTY-RSRY, UTY-RHRY, UTY-RSNYM

Wireless LAN Interface: UTY-TFSXZ1

Cassette Grille: UTY-UFYF-W

Fresh Air Intake Kit: UTZ-VXAA

Air Outlet Shutter Plate: UTR-YDZB

Insulation for High Humidity: UTZ-KXGC

External Input and Output PCB (with box): UTY-XCSX+UTZ-GXRA

External Connect Kit: UTY-XWZXZG

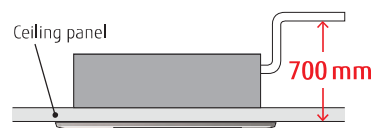

Dimensions

(Unit : mm)

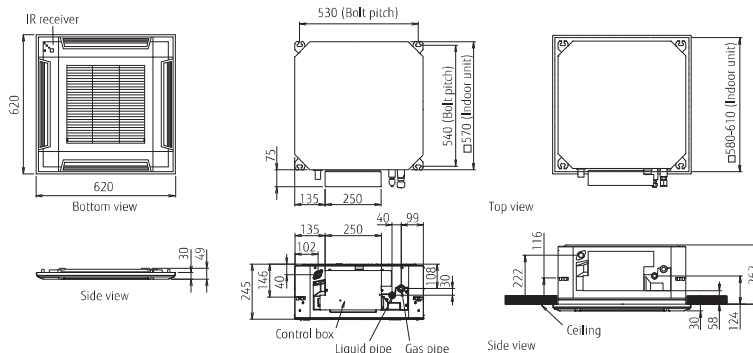

SPLIT

Compact Cassette

4-way Flow

Compact & Comfort



2-stage turbo fan

High efficiency design by 2 stage structure

Previous turbo fan

In the case of a conventional fan, the air outlet range was narrow as the airflow moved to the motor side which meant the velocity of air passing through the heat exchanger was uneven.



➔

Wind velocity



2-stage turbo fan

An evenly spread air distribution across the heat exchanger is possible due to the 2 stage turbo fan which produces two separate airflow streams.

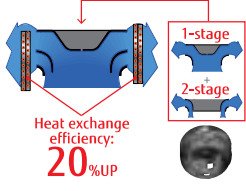

Heat exchange efficiency: **20%UP**

Quiet quality

Optimized wing form (laminar wing type) and wing number (7 blades each)

Designed by CFD-analysis (fluid) simulations

Laminar wing

Airflow runs through smoothly along the laminar wing



No airflow separation

Quiet

Adoption of laminar wing

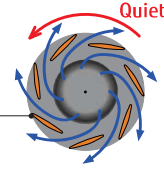

Quiet

Spin direction

Airflow direction

Improvement of the airflow distribution

The louver design distributes air leaving a space between the chassis and the ceiling allowing far and wide airflow distribution.

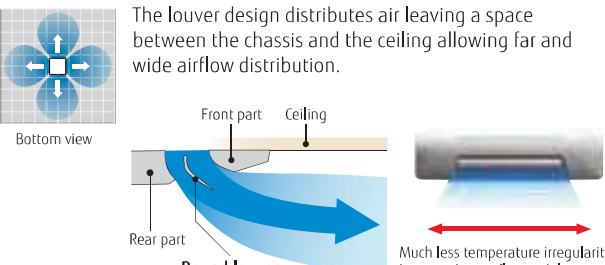

Bottom view

Front part Ceiling

Rear part

Round louver

Much less temperature irregularity by spreading airflow widely

Low ambient operation

-15°C
at Heating

Cooling 46°C

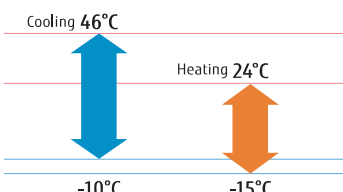

Heating 24°C

-10°C -15°C

Model : AUYG12LVLB / AUYG14LVLB / AUYG18LVLB / AUYG24LVLA



Wireless R.C.



For AUYG12/14LVLB



For AUYG18LVLB



For AUYG24LVLA

Specifications

Model No.	Indoor unit		AUYG12LVLB	AUYG14LVLB	AUYG18LVLB	AUYG24LVLA
	Outdoor unit		AOYG12LALL	AOYG14LALL	AOYG18LBCB	AOYG24LBCB
Power Source			Single-phase, ~230V, 50Hz			
Capacity	Cooling	kW	3.5 (0.9-4.4)	4.3 (0.9-5.4)	5.2 (0.9-5.9)	6.8 (0.9-8.0)
	Heating		4.1 (0.9-5.7)	5.0 (0.9-6.5)	6.0 (0.9-7.5)	8.0 (0.9-9.1)
Input Power	Cooling/Heating	kW	1.05/1.11	1.33/1.34	1.62/1.66	2.21/2.26
EER	Cooling	W/W	3.33	3.21	3.21	3.08
	Heating		3.69	3.71	3.61	3.54
Pdesign	Cooling/Heating(-10°C)	kW	3.5/4.2	4.3/4.5	5.2/5.2	6.8/6.0
SEER	Cooling	W/W	6.20	6.40	6.20	5.60
	Heating (Average)		4.10	4.40	4.20	3.90
Energy Efficiency Class	Cooling		A++	A++	A++	A+
	Heating (Average)		A+	A+	A+	A
Max. Operating Current	Cooling/Heating	A	7.5/10.0	9.0/12.5	11.5/13.5	14.7/15.7
Annual Energy Consumption	Cooling	kWh/a	198	235	293	425
	Heating		1,431	1,432	1,731	2,151
Moisture Removal		l/h	1.2	1.5	2.2	2.7
Sound Pressure Level	Indoor (Cooling)	H/M/L/Q	37/34/30/27	38/34/30/27	38/34/30/26	49/44/36/30
	Indoor (Heating)	H/M/L/Q	37/34/31/29	43/38/34/30	43/38/34/30	49/45/40/33
Sound Power Level	Outdoor(Cooling/Heating)	High	47/48	49/49	50/50	53/54
	Indoor(Cooling/Heating)	High	49/49	50/55	50/55	59/61
Airflow Rate	Outdoor(Cooling/Heating)	High	61/63	62/64	62/65	66/66
	Indoor / Outdoor (Cooling)	High	600/1,780	680/1,910	680/2,380	930/2,850
Net Dimensions H x W x D	Indoor / Outdoor (Heating)	High	600/1,630	800/1,740	800/2,080	930/2,700
	Indoor	mm	245×570×570	245×570×570	245×570×570	245×570×570
Weight	Outdoor	mm	578×790×300	578×790×300	632×799×290	716×820×315
	Indoor	kg(lbs)	15 (33)	15 (33)	15 (33)	16 (35)
Connection Pipe Diameter (Liquid / Gas)	Indoor	kg(lbs)	40 (88)	40 (88)	36 (79)	42 (95)
	Outdoor	kg(lbs)	6.35/9.52	6.35/12.70	6.35/12.70	6.35/15.88
Drain hose Diameter (I.D./O.D.)		mm	25/32	25/32	25/32	25/32
Max Pipe Length (Pre-Charge)		m	25 (15)	25 (15)	25 (15)	30 (15)
Max Height Difference			15	15	15	20
Operation Range	Cooling	°CDB	-10 to 46	-10 to 46	-10 to 46	-10 to 46
	Heating		-15 to 24	-15 to 24	-15 to 24	-15 to 24
Refrigerant	Type (Global Warming Potential)		R410A (2,088)	R410A (2,088)	R410A (2,088)	R410A (2,088)
	Charge	kg(CO2eq-T)	1.15 (2.4)	1.25 (2.6)	1.20 (2.5)	1.50 (3.1)
Cassette Grille	Model name		UTG-UFYD-W	UTG-UFYD-W	UTG-UFYD-W	UTG-UFYD-W
	Dimensions (H × W × D)	mm	49×700×700	49×700×700	49×700×700	49×700×700
	Weight	kg(lbs)	2.6 (6)	2.6 (6)	2.6 (6)	2.6 (6)

Optional parts

Wired Remote Controller:	UTY-RNNYM, UTY-RVNYM	Air Outlet Shutter Plate:	UTR-YDZB
Simple Remote Controller:	UTY-RSNYM	Wireless LAN Interface:	UTY-TFNXZ1
Insulation Kit For High Humidity:	UTZ-KXGC	External Connect Kit:	UTY-XWZX
Fresh Air Intake Kit:	UTZ-VXAA	Cassette Grille:	UTG-UFYD-W

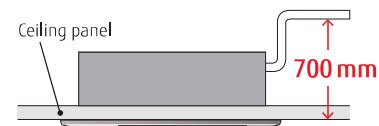

Dimensions

(Unit : mm)

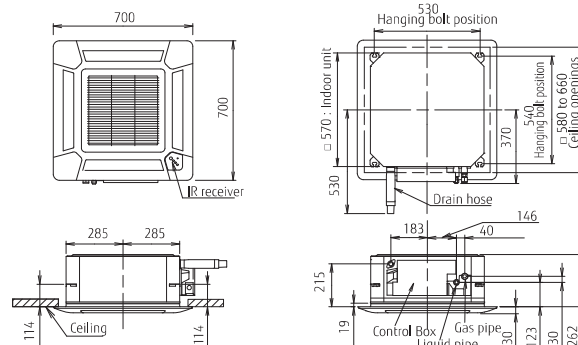

SPLIT

NEW

Cassette

Circular Flow

Comfort for Large Room



UTG-UKYA-B
Black Color Grille



Unique Circular Flow design

Cassette type realizes Circular Flow to blow large airflow in 360° direction by mounting high performance DC fan motor, turbo fan and unique seamless airflow louver design.



Comfortable air conditioning by preventing direct blowing of cold air and by providing swinging air flow simultaneously.

Efficient air conditioning based on the room layout

Individual louver control

Each louver can be set individually by Touch Panel Wired Remote Controller to enjoy the comfort of different directional airflows according to various room layouts.

*Touch Panel Wired RC (UTY-RNRYZ3)only

Human sensor increases more energy saving

Energy saving operation starts automatically by detecting the motion of a person. 2 modes of save operation mode and stop mode can be selected.

Compact and lightweight outdoor unit

45 model outdoor unit was changed completely. Easier installation was realized by compact and lightweight outdoor unit.

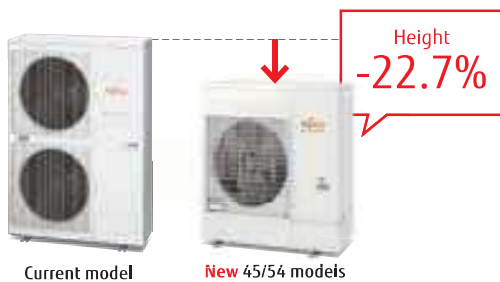

Low ambient operation

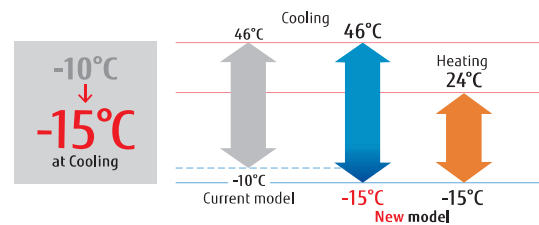

Various Cassette Grille

Both, black and white color grilles are available. There are three types: white color grille with Remote Controller, only white color grille and only black color grille. Selectable according to the atmosphere and/or usage of the room.



UTG-UKYA-W
White Color Grille
With touch panel wired remote controller

UTG-UKYA-B
Black Color Grille

UTG-UKYC-W
White Color Grille



**Model: AUXG18KRLB / AUXG22KRLB / AUXG24KRLB
AUXG30KRLB / AUXG36KRLB / AUXG45KRLB / AUXG54KRLB**



Specifications

Model No.	Indoor unit		AUXG18KRLB	AUXG22KRLB	AUXG24KRLB	AUXG30KRLB	AUXG36KRLB	AUXG45KRLB	AUXG54KRLB
	Outdoor unit		AOYG18KBTB	AOYG22KBTB	AOYG24KBTB	AOYG30KBTB	AOYG36KBTB	AOYG45KBTB	AOYG54KBTB
Power Source			Single-phase, ~230V, 50Hz						
Capacity	Cooling	kW	5.2 (0.9-5.9)	6.0 (0.9-6.7)	6.8 (0.9-8.0)	8.5 (2.8-10.0)	9.5 (2.8-11.2)	12.1 (4.0-14.0)	13.4 (4.5-14.5)
	Heating		6.0 (0.9-7.5)	7.0 (0.9-8.0)	7.5 (0.9-9.1)	10.0 (2.7-11.2)	10.8 (2.7-12.7)	13.5 (4.2-16.2)	15.5 (4.7-16.5)
Input Power	Cooling/Heating	kW	1.36/1.58	1.71/1.82	1.89/1.90	2.44/2.51	2.91/2.45	3.61/3.21	4.41/4.16
EER	Cooling	W/W	3.82	3.51	3.60	3.49	3.26	3.35	3.04
	Heating		3.80	3.85	3.95	3.98	4.40	4.20	3.73
Pdesign	Cooling/Heating(-10°C)	kW	5.2/4.4	6.0/4.8	6.8/6.0	8.5/8.0	9.5/8.7	-	-
SEER	Cooling	W/W	7.00	7.00	6.60	6.70	6.55	-	-
	Heating (Average)		4.30	4.40	4.20	4.30	4.30	-	-
Energy Efficiency Class	Cooling	A	A++	A++	A++	A++	A++	-	-
	Heating (Average)		A+	A+	A+	A+	A+	-	-
Max. Operating Current	Cooling/Heating	A	12.1	12.6	13.6	22.6	22.6	28.5	28.5
Annual Energy Consumption	Cooling	kWh/a	260	300	360	444	507	-	-
	Heating		1,431	1,527	1,999	2,601	2,828	-	-
Moisture Removal		l/h	1.5	2.2	2.7	2.5	3.3	4.5	5.0
Sound Pressure Level	Indoor (Cooling)	H/M/L/Q	33/32/31/28	33/32/31/28	35/33/32/29	40/38/36/33	44/41/38/34	46/42/39/35	47/43/40/36
	Indoor (Heating)	H/M/L/Q	33/32/31/28	33/32/31/28	35/33/32/29	40/38/36/33	44/41/38/34	46/42/39/35	47/43/40/36
Sound Power Level	Outdoor(Cooling/Heating)	High	50/50	51/51	53/54	53/55	55/55	57/57	57/59
	Indoor(Cooling/Heating)	High	47/47	49/49	49/49	54/54	58/58	60/60	61/61
Airflow Rate	Indoor / Outdoor (Cooling)	High	1,050/2,160	1,050/2,240	1,150/2,700	1,600/3,750	1,870/3,750	2,000/4,450	2,100/4,450
	Indoor / Outdoor (Heating)	High	1,050/1,830	1,050/1,960	1,150/2,700	1,600/3,750	1,870/3,750	2,000/4,450	2,100/4,450
Net Dimensions H x W x D	Indoor	mm	246x840x840	246x840x840	246x840x840	288x840x840	288x840x840	288x840x840	288x840x840
	Outdoor	mm	632x799x290	632x799x290	716x820x315	788x940x320	788x940x320	998x940x320	998x940x320
Weight	Indoor	kg(lbs)	23 (51)	23 (51)	24 (53)	26 (57)	29 (64)	29 (64)	29 (64)
	Outdoor	kg(lbs)	36 (79)	38 (84)	42 (93)	52 (115)	52 (115)	67 (148)	67 (148)
Connection Pipe Diameter (Liquid / Gas)		mm	6.35/12.70	6.35/12.70	6.35/12.70	9.52/15.88	9.52/15.88	9.52/15.88	9.52/15.88
Drain hose Diameter (I.D./O.D.)		mm	25/32	25/32	25/32	25/32	25/32	25/32	25/32
Max Pipe Length (Pre-Charge)		m	30 (20)	30 (20)	30 (20)	50 (30)	50 (30)	50 (30)	50 (30)
Max Height Difference			20	25	25	30	30	30	30
Operation Range	Cooling	°CDB	-15 to 46	-15 to 46	-15 to 46	-15 to 46	-15 to 46	-15 to 46	-15 to 46
	Heating		-15 to 24	-15 to 24	-15 to 24	-15 to 24	-15 to 24	-15 to 24	-15 to 24
Refrigerant	Type (Global Warming Potential)		R32 (675)	R32 (675)	R32 (675)	R32 (675)	R32 (675)	R32 (675)	R32 (675)
	Charge	kg(CO2eq-T)	1.02 (0.689)	1.25 (0.844)	1.25 (0.844)	1.90 (1.283)	1.90 (1.283)	2.70 (1.823)	2.70 (1.823)
Cassette Grille	Variation		UTG-UKYA-W: White Color with touch panel wired remote controller UTG-UKYC-W: White Color / UTG-UKYA-B*1: Black Color						
	Dimensions (H x W x D)	mm	53x950x950	53x950x950	53x950x950	53x950x950	53x950x950	53x950x950	53x950x950
	Weight	kg(lbs)	6.0 (13)	6.0 (13)	6.0 (13)	6.0 (13)	6.0 (13)	6.0 (13)	6.0 (13)

*1: IR Receiver kit and human sensor kit cannot be connected.

Optional parts

- Wired Remote Controller: UTY-RNRYZ3, UTY-RLRY, UTY-RVNYM, UTY-RNNYM
- Simple Remote Controller: UTY-RSRY, UTY-RHRY, UTY-RSNYM
- IR Receiver Kit: UTY-LBTYC
- Wireless LAN Interface: UTY-TFSXZ1
- Human Sensor Kit: UTY-SHZXC
- Cassette Grille: UTG-UKYA-W, UTG-UKYC-W, UTG-UKYA-B
- Wide Panel: UTG-AKXA-W
- Panel Spacer: UTG-BKXA-W
- Fresh Air Intake Kit: UTZ-VXRA
- Air Outlet Shutter Plate: UTR-YDZK
- Insulation Kit for High Humidity: UTZ-KXRA
- External Input and Output PCB (with box): UTY-XCSX + UTZ-GXRA
- External Connect Kit: UTY-XWZXZG



Dimensions

(Unit : mm)

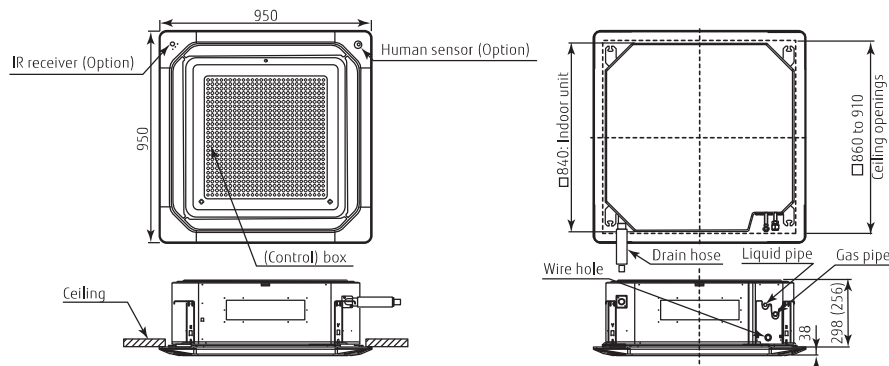

() : AUXG18/22/24KRLB

SPLIT

SPLIT

Cassette

Circular Flow

Comfort for Large Room



(30/36/45/54)

Unique Circular Flow design

Cassette type realizes Circular Flow to blow large airflow in 360° direction by mounting high performance DC fan motor, turbo fan and unique seamless airflow louver design.

- ø7mm high density heat exchanger
- DC fan motor
- High efficient turbo fan
- Seamless airflow louver



Individual louver control

Each louver can be set individually by Touch Panel Wired Remote Controller to enjoy the comfort of different directional airflows according to various room layouts.

*Touch Panel Wired RC (UTY-RNRYZ3) only



Comfortable air conditioning by preventing direct blowing of cold air and by providing swinging air flow simultaneously.

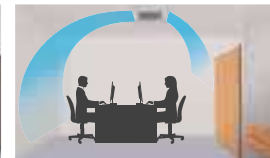

Efficient air conditioning based on the room layout

Human sensor increases more energy saving

Energy saving operation starts automatically by detecting the motion of a person. 2 modes of save operation mode and stop mode can be selected.

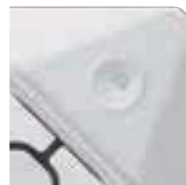

Human sensor (Option)

2 modes can be selected.

- Auto saving** Power is saved while people are away.
- Auto OFF** Operation stops after people go out.

*Touch Panel Wired RC (UTY-RNRYZ3) only

Various Cassette Grille

Both, black and white color grilles are available. There are three types: white color grille with Remote Controller, only white color grille and only black color grille. Selectable according to the atmosphere and/or usage of the room.



UTG-UKYA-W
White Color Grille
With touch panel wired remote controller



UTG-UKYA-B
Black Color Grille



UTG-UKYC-W
White Color Grille

**Model: AUXG18LRLB / AUXG24LRLB
AUXG30LRLB / AUXG36LRLB / AUXG45LRLB / AUXG54LRLB**



Specifications

Model No.	Indoor unit		AUXG18LRLB	AUXG24LRLB	AUXG30LRLB	AUXG36LRLB	AUXG45LRLB	AUXG54LRLB	
	Outdoor unit		AOYG18LBCA	AOYG24LBCA	AOYG30LBTA	AOYG36LBTA	AOYG45LBTA	AOYG54LBTA	
Power Source			Single-phase, ~230V, 50Hz						
Capacity	Cooling	kW	5.2 (0.9-6.5)	6.8 (0.9-8.0)	8.5 (2.8-10.0)	9.5 (2.8-11.2)	12.5 (4.0-14.0)	13.3 (4.5-14.5)	
	Heating		6.0 (0.9-8.0)	7.8 (0.9-9.1)	10.0 (2.7-11.2)	10.8 (2.7-12.7)	14.0 (4.2-16.2)	15.8 (4.7-16.5)	
Input Power	Cooling/Heating	kW	1.42/1.50	2.16/2.18	2.56/2.77	2.96/2.91	3.85/3.73	4.38/4.58	
EER	Cooling	W/W	3.66	3.15	3.32	3.21	3.25	3.04	
COP	Heating		4.00	3.58	3.61	3.71	3.75	3.45	
Pdesign	Cooling/Heating(-10°C)	kW	5.2/4.3	6.8/6.0	8.5/8.0	9.5/8.7	-	-	
SEER	Cooling	W/W	7.05	6.60	6.70	6.40	-	-	
SCOP	Heating (Average)		4.40	4.20	4.30	4.30	-	-	
Energy Efficiency Class	Cooling	A++		A++		A++		A++	
	Heating (Average)	A+		A+		A+		A+	
Max. Operating Current	Cooling/Heating	A	10.0/13.5	13.5/18.5	17.0/17.0	20.0/20.0	20.5/20.5	21.5/21.5	
Annual Energy Consumption	Cooling	kWh/a	258	361	444	519	-	-	
	Heating		1,367	1,999	2,604	2,833	-	-	
Moisture Removal		l/h	2.2	2.7	2.5	3.3	4.5	5.0	
Sound Pressure Level	Indoor (Cooling)	H/M/L/Q	33/32/31/28	35/33/32/29	40/38/36/33	44/41/38/34	46/42/39/35	47/43/40/36	
	Indoor (Heating)	H/M/L/Q	33/32/31/28	35/33/32/29	40/38/36/33	44/41/38/34	46/42/39/35	47/43/40/36	
Sound Power Level	Outdoor (Cooling/Heating)	High	51/50	55/56	53/55	54/55	55/55	55/57	
	Indoor (Cooling/Heating)	High	47/47	49/49	54/54	58/58	60/60	61/61	
Airflow Rate	Indoor / Outdoor (Cooling)	High	1,050/1,900	1,150/2,460	1,600/3,600	1,900/3,800	2,000/6,750	2,100/6,750	
	Indoor / Outdoor (Heating)	High	1,050/1,700	1,150/2,360	1,600/3,600	1,900/3,800	2,000/6,200	2,100/6,850	
Net Dimensions H x W x D	Indoor	mm	246×840×840	246×840×840	288×840×840	288×840×840	288×840×840	288×840×840	
	Outdoor	mm	620×790×290	620×790×290	830×900×330	830×900×330	1290×900×330	1290×900×330	
Weight	Indoor	kg(lbs)	24 (53)	24 (53)	26 (57)	26 (57)	29 (64)	29 (64)	
	Outdoor	kg(lbs)	41 (90)	41 (90)	61 (134)	61 (134)	86 (189)	86 (189)	
Connection Pipe Diameter (Liquid / Gas)		mm	6.35/12.7	6.35/15.88	9.52/15.88	9.52/15.88	9.52/15.88	9.52/15.88	
Drain hose Diameter (I.D./O.D.)		mm	25/32	25/32	25/32	25/32	25/32	25/32	
Max Pipe Length (Pre-Charge)		m	30 (15)	30 (15)	50 (20)	50 (20)	50 (20)	50 (20)	
Max Height Difference			20	20	30	30	30	30	
Operation Range	Cooling	*CDB	-15 to 46	-15 to 46	-15 to 46	-15 to 46	-15 to 46	-15 to 46	
	Heating		-15 to 24	-15 to 24	-15 to 24	-15 to 24	-15 to 24	-15 to 24	
Refrigerant	Type (Global Warming Potential)		R410A (2,088)	R410A (2,088)	R410A (2,088)	R410A (2,088)	R410A (2,088)	R410A (2,088)	
	Charge	kg(CO2eq-T)	1.80 (3.8)	1.80 (3.8)	2.10 (4.4)	2.10 (4.4)	3.35 (7.0)	3.35 (7.0)	
Cassette Grille	Variation	UTG-UKYA-W: White Color with touch panel wired remote controller UTG-UKYC-W: White Color / UTG-UKYA-B*: Black Color							
	Dimensions (H x W x D)	mm	53×950×950	53×950×950	53×950×950	53×950×950	53×950×950	53×950×950	
	Weight	kg(lbs)	6.0 (13)	6.0 (13)	6.0 (13)	6.0 (13)	6.0 (13)	6.0 (13)	

*1: IR Receiver kit and human sensor kit cannot be connected.

Optional parts

- Wired Remote Controller: UTY-RNRYZ3, UTY-RVNYM, UTY-RLRY, UTY-RNNYM
- Simple Remote Controller: UTY-RSNYM, UTY-RSRY, UTY-RHRY, UTY-LBTYC
- IR Receiver Kit: UTY-SHZXC
- Human Sensor Kit: UTY-SHZXC
- Wide Panel: UTG-AKXA-W
- Panel Spacer: UTG-BKXA-W
- Air Outlet Shutter Plate: UTR-YDZK
- Insulation Kit For High Humidity: UTZ-KXRA, UTZ-VXRA
- Flesh Air Intake Kit: UTY-XCSX + UTZ-GXRA
- External input and output PCB (with box): UTY-XWZXCZG
- External connect kit: UTY-XWZXCZG
- Cassette Grille: UTG-UKYA-W, UTG-UKYA-B, UTG-UKYC-W
- Wireless LAN Interface: UTY-TFNXZ1

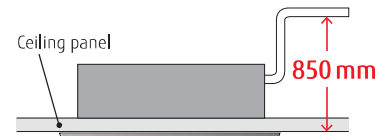

Dimensions

(Unit : mm)

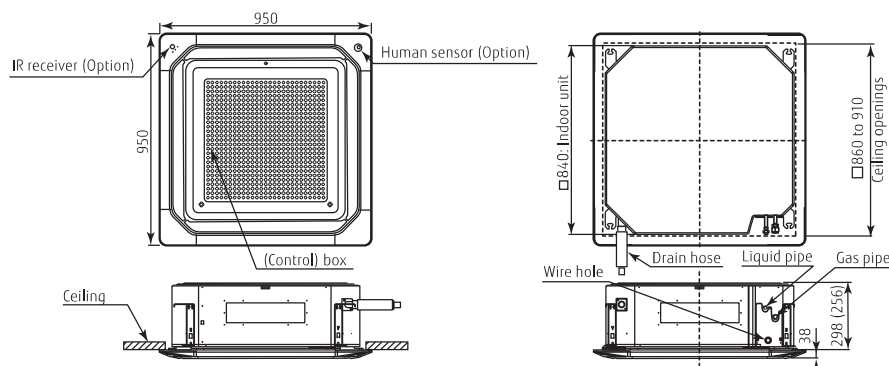

() : AUXG18/24LRLB

SPLIT

Cassette

4-way Flow

Comfort for large room



High efficiency turbo fan with 3-dimensional blade

Previous turbo fan: Air passing through the heat exchanger was uneven and the air would only flow close to the ceiling.

New turbo fan: High efficiency airflow distribution has been achieved by the introduction of a 3 dimensional blade which increases the air passing over the heat exchanger.

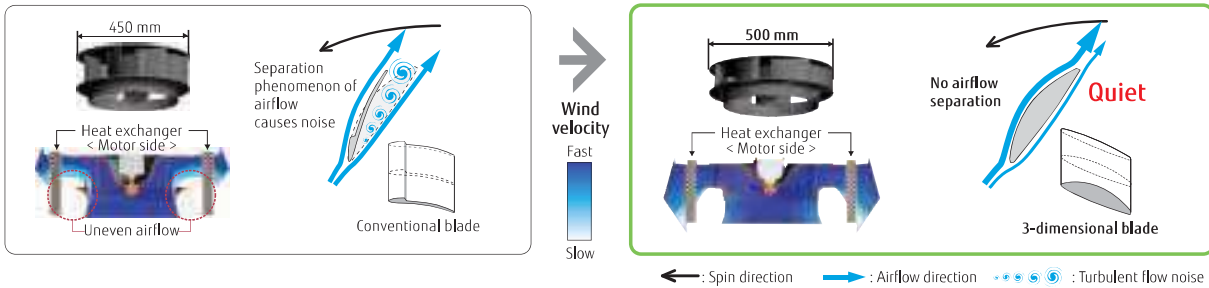

Improvement of the airflow distribution

The louver design distributes air leaving a space between the chassis and the ceiling allowing far and wide airflow distribution.

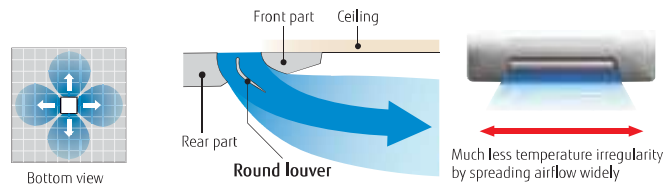

Adjustment of hanger position is possible after installation

Hanging bracket can be checked directly by removing the corner cover. Hanging position can be arranged easily.



Low ambient operation

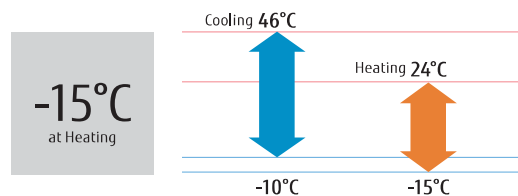

Model : AUYG30LRLE / AUYG36LRLE / AUYG45LRLE / AUYG54LRLE / AUYG36LRLA [3 phase] / AUYG45LRLA [3 phase] / AUYG54LRLA [3 phase]



Wired R.C.



For AUYG30/36LRLE



For AUYG45LRLE (Single-phase)



For AUYG36/45/54LRLA

Specifications

Model No.	Indoor unit		AUYG30LRLE	AUYG36LRLE	AUYG45LRLE	AUYG45LRLA	AUYG54LRLE	AUYG54LRLA	AUYG36LRLA	AUYG45LRLA	AUYG54LRLA
	Outdoor unit		AOYG30LETL	AOYG36LETL	AOYG45LBTCL	AOYG45LETL	AOYG54LETL	AOYG36LATT	AOYG45LATT	AOYG54LATT	
Power Source	Single-phase, ~230V, 50Hz						3-phase, ~400V, 50Hz				
Capacity	Cooling	kW	8.5 (2.8-10.0)	10.0 (2.8-11.2)	12.1 (4.0-13.5)	12.5 (4.0-14.0)	13.3 (4.5-14.5)	10.0 (4.7-11.4)	12.5 (5.0-14.0)	14.0 (5.4-16.0)	
	Heating		10.0 (2.7-11.2)	11.2 (2.7-12.7)	13.5 (4.2-15.7)	14.0 (4.2-16.2)	16.0 (4.7-16.5)	11.2 (5.0-14.0)	14.0 (5.4-16.2)	16.0 (5.8-18.0)	
Input Power	Cooling/Heating	kW	2.65/2.77	3.12/3.02	3.89/3.85	3.88/3.77	4.42/4.69	2.44/2.56	3.54/3.58	4.36/4.43	
	Cooling		3.21	3.21	3.11	3.22	3.01	4.10	3.53	3.21	
COP	Cooling	W/W	3.61	3.71	3.51	3.71	3.41	4.38	3.91	3.61	
	Heating		-	-	-	-	-	-	-	-	
Pdesign	Cooling/Heating(-10°C)	kW	8.5/8.0	10.0/8.7	-	-	-	10.0/10.0	-	-	
SEER	Cooling	W/W	6.50	6.30	-	-	-	6.50	-	-	
	Heating (Average)		4.30	4.20	-	-	-	4.30	-	-	
Energy Efficiency Class	Cooling	A	A++	A++	-	-	-	A++	-	-	
	Heating (Average)		A+	A+	-	-	-	A+	-	-	
Max. Operating Current	Cooling/Heating	A	17.0/17.0	18.5/20.0	23.5/23.5	20.5/20.5	21.5/21.5	7.9/7.9	8.9/8.9	9.9/9.9	
	Cooling		458	555	-	-	-	538	-	-	
Annual Energy Consumption	Cooling	kWh/a	2,604	2,897	-	-	-	3,253	-	-	
	Heating		2.5	3.5	4.5	4.5	5.0	3.0	4.5	5.0	
Moisture Removal	Indoor (Cooling)	l/h	4.0	5.0	6.0	6.0	6.0	4.0	5.0	6.0	
	Indoor (Heating)		4.0	5.0	6.0	6.0	6.0	4.0	5.0	6.0	
Sound Pressure Level	Indoor (Cooling/Heating)	dB(A)	53/55	54/55	58/58	55/55	55/57	51/53	54/54	55/56	
	Outdoor (Cooling/Heating)		54/54	57/57	-	-	-	58/58	-	-	
Sound Power Level	Indoor (Cooling/Heating)	High	68/69	69/70	-	-	-	67/69	-	-	
	Outdoor (Cooling/Heating)		1,600/3,600	1,800/3,800	1,900/4,650	1,900/6,750	2,000/6,750	1,800/6,200	1,900/6,750	2,000/6,900	
Airflow Rate	Indoor / Outdoor (Cooling)	m ³ /h	1,600/3,600	1,800/3,800	1,900/4,650	1,900/6,200	2,000/6,850	1,800/6,200	1,900/6,200	2,000/6,900	
	Indoor / Outdoor (Heating)		288x840x840	288x840x840	288x840x840	288x840x840	288x840x840	288x840x840	288x840x840	288x840x840	
Net Dimensions H x W x D	Indoor	mm	830x900x330	830x900x330	914x970x370	1,290x900x330	1,290x900x330	1,290x900x330	1,290x900x330	1,290x900x330	
	Outdoor		26 (57)	26 (57)	26 (57)	26 (57)	26 (57)	26 (57)	26 (57)	26 (57)	
Weight	Indoor	kg (lbs)	61 (135)	61 (135)	75 (165)	86 (190)	86 (190)	104 (229)	104 (229)	104 (229)	
	Outdoor		9.52/15.88	9.52/15.88	9.52/15.88	9.52/15.88	9.52/15.88	9.52/15.88	9.52/15.88	9.52/15.88	
Connection Pipe Diameter (Liquid / Gas)	mm		25.0/32.0	25.0/32.0	25.0/32.0	25.0/32.0	25.0/32.0	25.0/32.0	25.0/32.0		
Drain hose Diameter (I.D./O.D.)	mm		50 (20)	50 (20)	50 (20)	50 (20)	50 (20)	75 (30)	75 (30)	75 (30)	
Max Pipe Length (Pre-Charge)	m		30	30	30	30	30	30	30	30	
Max Height Difference	Cooling	°CDB	-15 to 46	-15 to 46	-15 to 46	-15 to 46	-15 to 46	-15 to 46	-15 to 46	-15 to 46	
	Heating		-15 to 24	-15 to 24	-15 to 24	-15 to 24	-15 to 24	-15 to 24	-15 to 24	-15 to 24	
Refrigerant	Type (Global Warming Potential)	kg(CO ₂ eq-1)	R410A (2,088)	R410A (2,088)	R410A (2,088)	R410A (2,088)	R410A (2,088)	R410A (2,088)	R410A (2,088)	R410A (2,088)	
	Charge		2.10 (4.4)	2.10 (4.4)	2.90 (6.1)	3.35 (7.0)	3.35 (7.0)	3.45 (7.2)	3.45 (7.2)	3.45 (7.2)	
Cassette Grille	Model name	mm	UTG-UGYA-W	UTG-UGYA-W	UTG-UGYA-W	UTG-UGYA-W	UTG-UGYA-W	UTG-UGYA-W	UTG-UGYA-W	UTG-UGYA-W	
	Dimensions (H x W x D)		50x950x950	50x950x950	50x950x950	50x950x950	50x950x950	50x950x950	50x950x950	50x950x950	
	Weight	kg (lbs)	5.5 (12)	5.5 (12)	5.5 (12)	5.5 (12)	5.5 (12)	5.5 (12)	5.5 (12)	5.5 (12)	

Optional parts

- Wired Remote Controller: UTY-RNNYM, UTY-RVNYM
- Simple Remote Controller: UTY-RSNYM
- IR Receiver Kit: UTY-LRHYA2
- Wide Panel: UTG-AKXA-W
- Panel Spacer: UTG-BKXA-W
- Air Outlet Shutter Plate: UTR-YDZX
- Insulation Kit For High Humidity: UTZ-KXRA
- Fresh Air Intake Kit: UTZ-VXRA
- Wireless LAN Interface: UTY-TFNXZ1
- External Connect Kit: UTY-XWZX
- Cassette Grille: UTG-UGYA-W

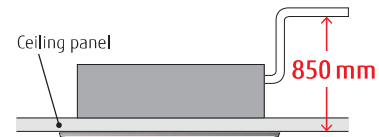

Dimensions

(Unit : mm)

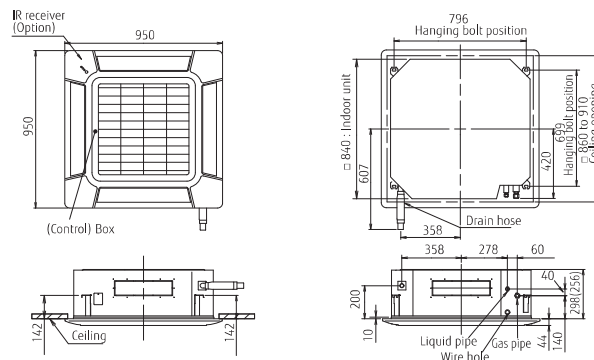

SPLIT

Mini Duct

Built-in Drain Pump



Large living space available

- Installation space can be reduced down to minimum depth 450 mm height 198 mm and compact design
- Minimum size: Depth 450 mm, Height 198 mm Volume 27% down compared with current model
- Lightweight: 15.5 kg 18% down (12/14 models)

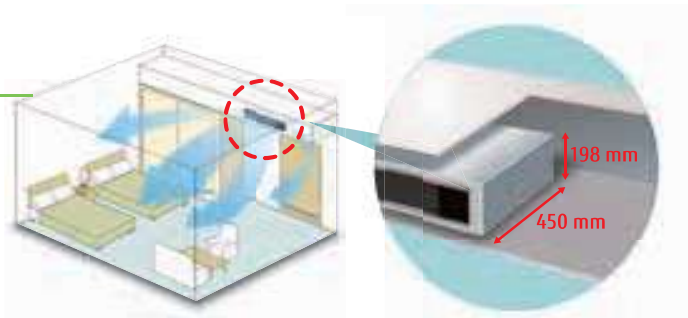

Optimum airflow path and low noise operation

Low noise is realized drastically by stabilized airflow design

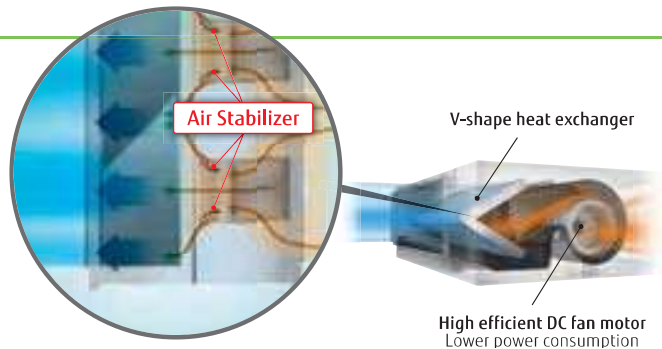

Easy design and maintenance for drain

By using the DC fan motor, it is possible to change the static pressure range from 0 to 50 Pa*. The change of static pressure range is possible by remote controller.
*12 model: 0 to 30 Pa.

Built-in drain pump as standard:
Maintenance is easy

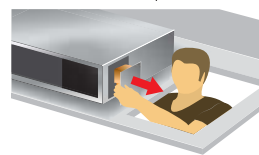

Parts can be replaced from the side of the body where maintenance is easier

Auto Louver Grille Kit (Option)

- Thin design provides a comfortable living environment over a wide area.
- Automatic louver grille provides comfortable air conditioning all the way down to the floor and matches the interior design well. (Optional)



Model : ARYG12LSLAP / ARYG14LSLAP / ARYG18LSLAP



ARYG12/14LSLAP



ARYG18LSLAP



Wired R.C.



For ARYG12/14LSLAP



For ARYG18LSLAP

Specifications

Model No.	Indoor unit		ARYG12LSLAP	ARYG14LSLAP	ARYG18LSLAP
	Outdoor unit		AOYG12LALL	AOYG14LALL	AOYG18LBCB
Power Source	Single-phase, ~230V, 50Hz				
Capacity	Cooling	kW	3.5 (0.9-4.4)	4.3 (0.9-5.4)	5.2 (0.9-5.9)
	Heating		4.1 (0.9-5.7)	5.0 (0.9-6.5)	6.0 (0.9-7.5)
Input Power	Cooling/Heating	kW	1.03/1.15	1.34/1.49	1.62/1.77
EER	Cooling	W/W	3.40	3.21	3.21
COP	Heating		3.56	3.35	3.38
Pdesign	Cooling/Heating(-10°C)	kW	3.5/4.2	4.3/4.5	5.2/5.2
SEER	Cooling	W/W	5.70	5.60	5.80
SCOP	Heating		3.90	3.80	3.80
Energy Efficiency Class	Cooling		A+	A+	A+
	Heating		A	A	A
Max. Operating Current	Cooling/Heating	A	7.5/10.0	9.0/12.5	11.5/13.5
Annual Energy Consumption	Cooling		215	269	314
	Heating		1,505	1,656	1,913
Moisture Removal		l/h	1.2	1.4	1.8
Sound Pressure Level	Indoor (Cooling)	H/M/L/Q	31/27/25/23	35/30/27/23	33/29/26/23
	Indoor (Heating)	H/M/L/Q	31/27/25/23	35/30/27/23	33/29/26/23
	Outdoor (Cooling/Heating)	High	47/48	49/49	50/50
Sound Power Level	Indoor (Cooling/Heating)	High	55/57	60/62	58/59
	Outdoor (Cooling/Heating)	High	61/63	62/64	62/65
Airflow Rate	Indoor / Outdoor (Cooling)	High	650/1,780	800/1,910	940/2,000
	Indoor / Outdoor (Heating)	High	650/1,630	800/1,740	940/1,910
Static pressure range (Standard)		Pa	0 to 30 (10)	0 to 50 (15)	0 to 50 (15)
Net Dimensions H x W x D	Indoor	mm	198×700×450	198×700×450	198×900×450
	Outdoor	mm	578×790×300	578×790×300	632×799×290
Weight	Indoor	kg(lbs)	15.5 (34)	15.5 (34)	18.5 (41)
	Outdoor	kg(lbs)	40 (88)	40 (88)	36 (79)
Connection Pipe Diameter (Liquid / Gas)		mm	6.35/9.52	6.35/12.70	6.35/12.70
Drain hose Diameter (I.D./O.D.)		mm	25/32	25/32	25/32
Max Pipe Length (Pre-Charge)		m	25 (15)	25 (15)	25 (15)
Max Height Difference			15	15	15
Operation Range	Cooling		-10 to 46	-10 to 46	-10 to 46
	Heating		-15 to 24	-15 to 24	-15 to 24
Refrigerant	Type (Global Warming Potential)		R410A (2,088)	R410A (2,088)	R410A (2,088)
	Charge	kg(CO2eq-T)	1.15 (2.4)	1.25 (2.6)	1.20 (2.5)

Optional parts

- Wired Remote Controller: UTY-RLRY, UTY-RNRVZ3, UTY-RVNYM, UTY-RNNYM
- Simple Remote Controller: UTY-RSNYM, UTY-RSRY, UTY-RHRY
- IR Receiver Kit: UTY-LBTYM
- Remote Sensor Unit: UTY-XSZX
- Auto Louver Grille Kit: UTD-GXTA-W (ARYG12/14LSLAP), UTD-GXTB-W (ARYG18LSLAP)
- External connect kit: UTY-XWZXZG
- Wireless LAN Interface: UTY-TFNXZ1

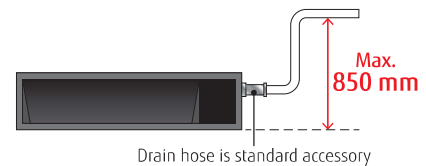

Dimensions

(Unit : mm)

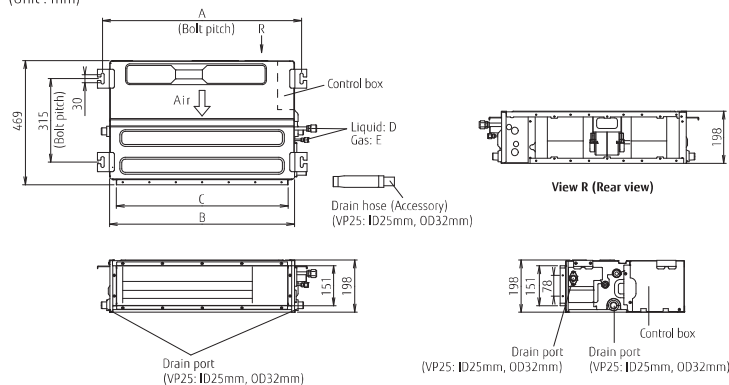

	ARYG12/14LSLAP	ARYG18LSLAP
A	752	952
B	700	900
C	650	850
D	6.35	9.52
E	12.70	15.88

SPLIT

NEW

Slim Duct

Slim & Comfort



Slim design

The slim design allows installations where ceilings are narrow. Drain hose as standard accessory



Height **198 mm**
Drain pump **built-in**

Compact and lightweight outdoor unit

Compact and lightweight outdoor unit expands a wider range of choice for installation location. This makes it easier to use this outdoor unit.



Selectable with a wide range of static pressure

By using the DC fan motor, it is possible to change the static pressure range from 0 to 90 Pa. The change of static pressure range is possible by remote controller.



Static pressure range **0 to 90 Pa**

Auto Louver Grille Kit (Option)

Simple flat Auto Louver will provide comfort airflow and harmonize with luxury interior.



Low ambient operation

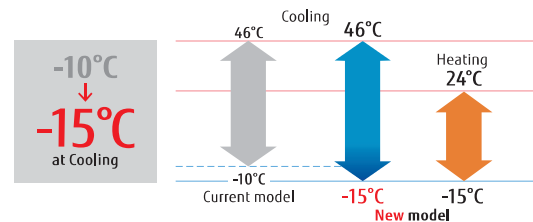

Model : ARXG09KLLAP / ARXG12KLLAP / ARXG14KLLAP / ARXG18KLLAP



ARXG09/12/14KLLAP



ARXG18KLLAP



For ARXG09/12/14KLLAP For ARXG18KLLAP

Specifications

Model No.	Indoor unit		ARXG09KLLAP	ARXG12KLLAP	ARXG14KLLAP	ARXG18KLLAP
	Outdoor unit		AOYG09KBTB	AOYG12KBTB	AOYG14KBTB	AOYG18KBTB
Power Source			Single-phase, ~230V, 50Hz			
Capacity	Cooling	kW	2.5 (0.9-3.2)	3.5 (0.9-4.4)	4.3 (0.9-5.4)	5.2 (0.9-5.9)
	Heating		3.2 (0.9-4.7)	4.1 (0.9-5.7)	5.0 (0.9-6.5)	6.0 (0.9-7.5)
Input Power	Cooling/Heating		0.60/0.79	0.93/1.08	1.28/1.32	1.55/1.62
	Cooling	W/W	4.17	3.76	3.36	3.35
COP	Heating		4.05	3.80	3.79	3.70
Pdesign	Cooling/Heating(-10°C)		2.5/2.6	3.5/3.4	4.3/3.8	5.2/4.4
SEER	Cooling		6.20	6.10	5.80	6.20
SCOP	Heating		4.30	4.00	3.90	4.10
Energy Efficiency Class	Cooling		A++	A++	A+	A++
	Heating		A+	A+	A	A+
Max. Operating Current	Cooling/Heating		7.9	9.7	10.2	12.1
Annual Energy Consumption	Cooling		141	201	259	293
	Heating		845	1,189	1,362	1,501
Moisture Removal			0.7	1.3	1.5	2.0
Sound Pressure Level	Indoor (Cooling)	H/M/L/Q	28/27/26/25	29/28/26/25	32/30/28/26	32/30/29/27
	Indoor (Heating)	H/M/L/Q	28/26/25/24	29/28/26/24	32/30/28/25	32/30/29/27
	Outdoor (Cooling/Heating)	High	46/46	47/47	49/49	50/50
Sound Power Level	Indoor (Cooling/Heating)	High	57/57	58/58	60/60	58/58
	Outdoor (Cooling/Heating)	High	59/59	61/61	62/62	62/62
	Indoor / Outdoor (Cooling)	High	600/1,480	650/1,580	800/1,670	940/2,160
Airflow Rate	Indoor / Outdoor (Heating)		600/1,410	650/1,520	800/1,580	940/1,830
	Static pressure range (Standard)		Pa	0 to 90 (25)	0 to 90 (25)	0 to 90 (25)
Net Dimensions H x W x D	Indoor	mm	198x700x620	198x700x620	198x700x620	198x900x620
	Outdoor	mm	542x799x290	542x799x290	542x799x290	632x799x290
Weight	Indoor	kg(lbs)	17 (37)	17 (37)	17 (37)	20 (44)
	Outdoor	kg(lbs)	32 (71)	33 (73)	33 (73)	36 (79)
Connection Pipe Diameter (Liquid / Gas)			6.35/9.53	6.35/9.53	6.35/9.53	6.35/12.70
Drain hose Diameter (I.D./O.D.)			25/32	25/32	25/32	25/32
Max Pipe Length (Pre-Charge)			20 (15)	25 (15)	25 (15)	30 (20)
Max Height Difference			15	20	20	20
Operation Range	Cooling		-15 to 46	-15 to 46	-15 to 46	-15 to 46
	Heating		-15 to 24	-15 to 24	-15 to 24	-15 to 24
Refrigerant	Type (Global Warming Potential)		R32 (675)	R32 (675)	R32 (675)	R32 (675)
	Charge	kg(CO2eq-T)	0.85 (0.574)	0.85 (0.574)	0.85 (0.574)	1.02 (0.689)

Optional parts

- Wired Remote Controller: UTY-RNRYZ3, UTY-RLRY, UTY-RVNYM, UTY-RNNYM
- Simple Remote Controller: UTY-RSRY, UTY-RHRY, UTY-RSNYM
- IR Receiver Kit: UTY-LBTYM
- Wireless LAN Interface: UTY-TFSXZ1
- Remote Sensor Unit: UTY-XSZX
- Auto Louver Grille Kit: UTD-GXTA-W (ARXG12/14KLLAP), UTD-GXTB-W (ARXG18KLLAP)
- External Connect Kit: UTY-XWZXZG

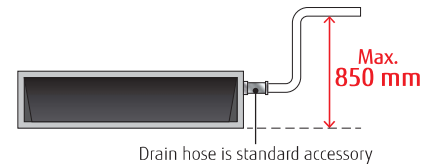

Dimensions

(Unit : mm)

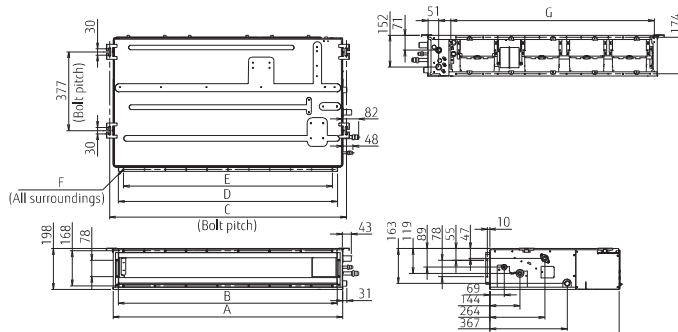

	ARXG09/12/14KLLAP	ARXG18KLLAP
A	700	900
B	650	850
C	734	934
D	650	850
E	P100x6-600	P100x8-800
F	18xØ5	22xØ5
G	574	774

SPLIT

Slim Duct

Slim & Comfort



Slim design

The slim design allows installations where ceilings are narrow. Drain hose as standard accessory

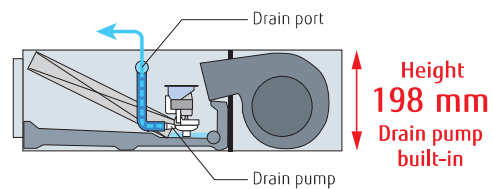

Flexible installation

2-type installation methods of ceiling concealed and floor concealed can be selected.

Ceiling concealed

Floor concealed



Selectable with a wide range of static pressure

By using the DC fan motor, it is possible to change the static pressure range from 0 to 90 Pa. The change of static pressure range is possible by remote controller.



Static pressure range
0 to 90 Pa

Auto Louver Grille Kit (Option)

Simple flat Auto Louver will provide comfort airflow and harmonize with luxury interior.

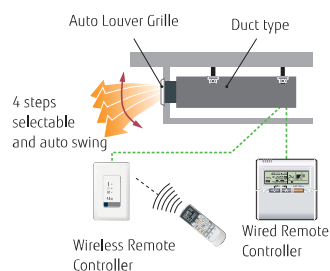

Low ambient operation

-15°C
at Heating

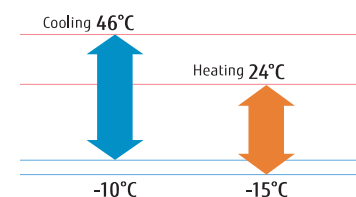

Model : ARYG12LLTB / ARYG14LLTB / ARYG18LLTB



ARYG12/14LLTB



ARYG18LLTB



Wired R.C.



For ARYG12/14LLTB



For ARYG18LLTB

Specifications

Model No.	Indoor unit		ARYG12LLTB	ARYG14LLTB	ARYG18LLTB
	Outdoor unit		AOYG12LALL	AOYG14LALL	AOYG18LBCB
Power Source			Single-phase, ~230V, 50Hz		
Capacity	Cooling	kW	3.5 (0.9-4.4)	4.3 (0.9-5.4)	5.2 (0.9-5.9)
	Heating		4.1 (0.9-5.7)	5.0 (0.9-6.5)	6.0 (0.9-7.5)
Input Power	Cooling/Heating		1.05/1.11	1.33/1.34	1.62/1.66
	Cooling	W/W	3.33	3.21	3.21
EER	Heating		3.69	3.71	3.61
Pdesign	Cooling/Heating(-10°C)		3.5/4.2	4.3/4.5	5.2/5.2
	Cooling	W/W	5.90	5.80	6.20
SEER	Heating		4.00	3.90	4.10
SCOP	Cooling		A+	A+	A++
	Heating		A+	A	A+
Max. Operating Current	Cooling/Heating	A	7.5/10.0	9.0/12.5	11.5/13.5
Annual Energy Consumption	Cooling		207	259	294
	Heating		1,467	1,614	1,775
Moisture Removal			1.3	1.5	2.0
	Indoor (Cooling)	H/M/L/Q	29/28/26/25	32/30/28/26	32/30/29/27
Sound Pressure Level	Indoor (Heating)	H/M/L/Q	29/28/26/24	32/30/28/25	32/30/29/27
	Outdoor(Cooling/Heating)	High	47/48	49/49	50/50
Sound Power Level	Indoor(Cooling/Heating)	High	58/58	60/60	58/58
	Outdoor(Cooling/Heating)	High	61/63	62/64	62/65
Airflow Rate	Indoor / Outdoor (Cooling)	High	650/1,780	800/1,910	940/2,380
	Indoor / Outdoor (Heating)	High	650/1,630	800/1,740	940/2,080
Static pressure range (Standard)			0 to 90 (25)	0 to 90 (25)	0 to 90 (25)
Net Dimensions H x W x D	Indoor	mm	198*700*620	198*700*620	198*900*620
	Outdoor	mm	578*790*300	578*790*300	632*799*290
Weight	Indoor	kg(lbs)	19 (42)	19 (42)	23 (51)
	Outdoor	kg(lbs)	40 (88)	40 (88)	36 (79)
Connection Pipe Diameter (Liquid / Gas)			6.35/9.52	6.35/12.70	6.35/12.70
Drain hose Diameter (I.D./O.D.)			25/32	25/32	25/32
Max Pipe Length (Pre-Charge)			25 (15)	25 (15)	25 (15)
Max Height Difference			15	15	15
Operation Range	Cooling	°CDB	-10 to 46	-10 to 46	-10 to 46
	Heating		-15 to 24	-15 to 24	-15 to 24
Refrigerant	Type (Global Warming Potential)		R410A (2,088)	R410A (2,088)	R410A (2,088)
	Charge	kg(CO2eq-T)	1.15 (2.4)	1.25 (2.6)	1.20 (2.5)

Optional parts

- Wired Remote Controller: UTY-RNNYM, UTY-RVNYM
- Simple Remote Controller: UTY-RSNYM
- IR Receiver Kit: UTY-LRHYM
- Remote Sensor Unit: UTY-XSZX
- Auto Louver Grille Kit: UTD-GXTA-W (ARYG12 / 14LLTB)
UTD-GXTB-W (ARYG18LLTB)
- External connect kit: UTD-ECSSA
- Wireless LAN Interface: UTY-TFNXZ1

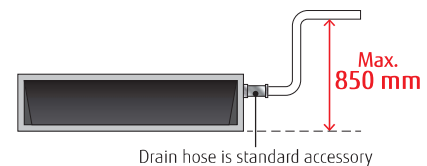

Dimensions

(Unit : mm)

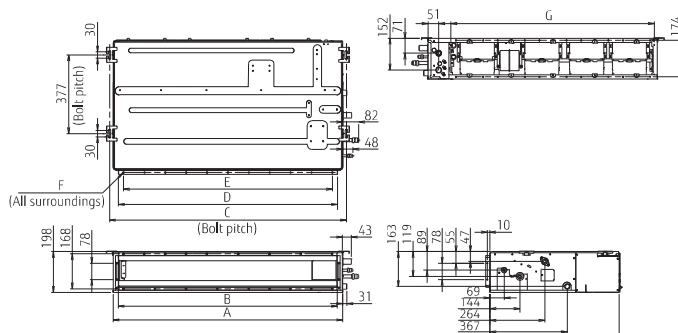

	ARYG12 / 14LLTB	ARYG18LLTB
A	700	900
B	650	850
C	734	934
D	650	850
E	P100x6-600	P100x8-800
F	18xØ5	22xØ5
G	574	774

SPLIT

NEW

Medium Static Pressure Duct

Compact & Comfort

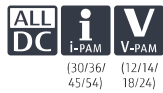

High Efficiency & Quiet operation

The combination of the V-shaped heat exchanger, air stabilizer, and the high efficient DC fan motor allowed high efficiency and quiet operation.

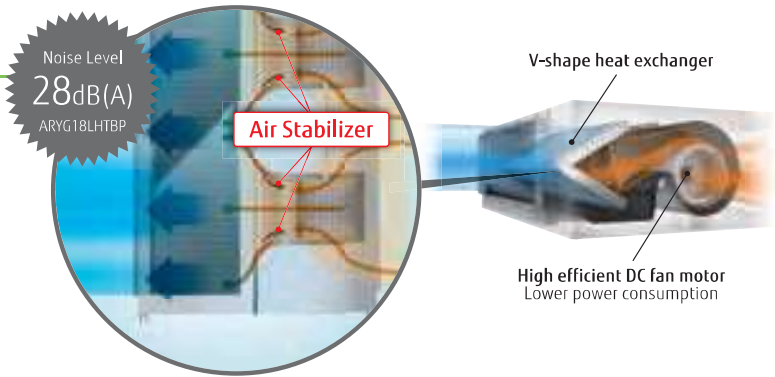

Small and light weight outdoor unit

This model is much more compact than conventional outdoor unit. It can be installed in a narrow place.

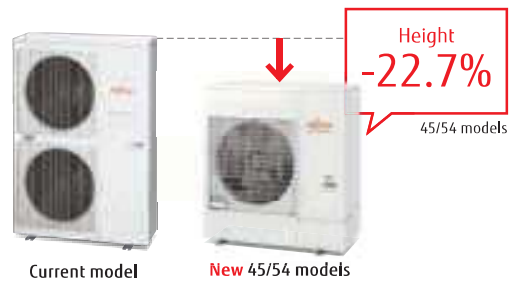

Automatic Airflow adjustment function

This unique and innovative function detects required air flow in each application case and automatically adjust the volume.



Low ambient operation

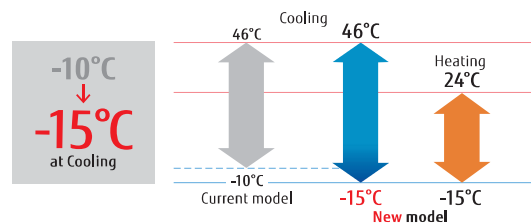



**Model: ARXG12KHTAP / ARXG14KHTAP / ARXG18KHTAP / ARXG22KHTAP / ARXG24KHTAP
ARXG30KHTAP / ARXG36KHTAP / ARXG45KHTAP / ARXG54KHTAP**



ARXG12/14KHTAP



ARXG18/22/24/30KHTAP

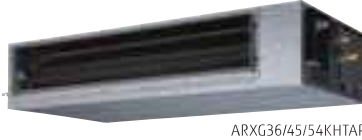

ARXG36/45/54KHTAP



For ARXG12/14KHTAP For ARXG18/22KHTAP For ARXG24KHTAP For ARXG30/36KHTAP For ARXG45/54KHTAP

Specifications

Model No.	Indoor unit		ARXG12KHTAP	ARXG14KHTAP	ARXG18KHTAP	ARXG22KHTAP	ARXG24KHTAP	ARXG30KHTAP	ARXG36KHTAP	ARXG45KHTAP	ARXG54KHTAP
	Outdoor unit		AOYG12KBTB	AOYG14KBTB	AOYG18KBTB	AOYG22KBTB	AOYG24KBTB	AOYG30KBTB	AOYG36KBTB	AOYG45KBTB	AOYG54KBTB
Power Source	Single-phase, ~230V, 50Hz										
Capacity	Cooling	kW	3.5 (0.9-4.4)	4.3 (0.9-5.4)	5.2 (0.9-5.9)	6.0 (0.9-6.7)	6.8 (0.9-8.0)	8.5 (2.8-10.0)	9.5 (2.8-11.2)	12.1 (4.0-14.0)	13.4 (4.5-14.5)
	Heating		4.1 (0.9-5.7)	5.0 (0.9-6.5)	6.0 (0.9-7.5)	7.0 (0.9-8.0)	7.5 (0.9-9.1)	10.0 (2.7-11.2)	10.8 (2.7-12.7)	13.5 (4.2-16.2)	15.5 (4.7-16.5)
Input Power	Cooling/Heating	kW	0.87/1.00	1.17/1.25	1.36/1.56	1.71/1.81	1.89/1.85	2.65/2.63	2.86/2.48	3.53/3.37	4.42/3.89
	EER		W/W	4.02	3.68	3.82	3.51	3.60	3.21	3.32	3.43
COP	Cooling	W/W		4.10	4.00	3.85	3.87	4.06	3.80	4.35	4.01
	Heating		3.5/3.4	4.3/3.8	5.2/4.4	6.0/4.8	6.8/6.0	8.5/8.0	9.5/8.7	-	-
Pdesign	Cooling/Heating(-10°C)	kW	3.5/3.4	4.3/3.8	5.2/4.4	6.0/4.8	6.8/6.0	8.5/8.0	9.5/8.7	-	-
	SEER		W/W	6.30	6.20	6.50	6.50	6.50	6.23	6.10	-
SCOP	Cooling	W/W		4.10	4.00	4.10	4.20	4.10	4.00	4.20	-
	Heating (Average)		A++	A++	A++	A++	A++	A++	A++	-	-
Energy Efficiency Class	Cooling	A	A+	A+	A+	A+	A+	A+	A+	-	-
	Heating (Average)		9.7	10.2	12.1	12.6	13.6	22.6	22.6	28.5	28.5
Max. Operating Current	Cooling/Heating	kWh/a	194	243	280	323	366	477	544	-	-
	Annual Energy Consumption		1,159	1,328	1,501	1,597	2,048	2,796	2,898	-	-
Moisture Removal	Cooling	l/h	0.7	0.9	1.2	1.5	1.8	2.3	2.0	2.6	3.7
	Heating		32/27/26/24	33/28/27/25	28/25/22/20	28/25/22/20	32/28/24/21	36/33/30/29	36/31/28/26	39/35/31/29	39/35/31/29
Sound Pressure Level	Indoor (Cooling)	H/M/L/Q	32/27/26/24	33/28/27/25	28/25/22/20	28/25/22/20	32/28/24/21	36/33/30/29	36/31/28/26	39/35/31/29	39/35/31/29
	Indoor (Heating)		47/47	49/49	50/50	51/51	53/54	53/55	55/55	57/57	57/59
Sound Power Level	Outdoor(Cooling/Heating)	High	57/58	59/60	54/54	57/57	57/57	63/65	64/63	67/69	67/69
	Indoor(Cooling/Heating)		61/61	62/62	62/62	63/63	65/66	68/69	70/70	71/71	73/73
Airflow Rate	Indoor / Outdoor (Cooling)	m³/h	850/1,580	950/1,670	1,050/2,160	1,050/2,240	1,360/2,700	1,700/3,750	2,050/3,750	2,550/4,450	2,550/4,450
	Indoor / Outdoor (Heating)		850/1,520	950/1,580	1,050/1,830	1,050/1,960	1,360/2,700	1,700/3,750	2,050/3,750	2,550/4,450	2,550/4,450
Static pressure range (Standard)	Indoor	Pa	30 to 200 (35)	30 to 200 (35)	30 to 200 (35)	30 to 200 (35)	30 to 200 (35)	30 to 200 (47)	30 to 200 (60)	30 to 200 (60)	
	Outdoor		300x700x700	300x700x700	300x1,000x700	300x1,000x700	300x1,000x700	300x1,000x700	300x1,400x700	300x1,400x700	300x1,400x700
Net Dimensions H x W x D	Indoor	mm	542x799x290	542x799x290	632x799x290	632x799x290	716x820x315	788x940x320	788x940x320	998x940x320	998x940x320
	Outdoor		27 (60)	27 (60)	35 (77)	35 (77)	36 (79)	36 (79)	46 (101)	46 (101)	46 (101)
Weight	Indoor	kg(lbs)	33 (73)	33 (73)	36 (79)	38 (84)	42 (93)	52 (115)	52 (115)	67 (148)	67 (148)
	Outdoor		6.35/9.53	6.35/9.53	6.35/12.70	6.35/12.70	6.35/12.70	9.52/15.88	9.52/15.88	9.52/15.88	9.52/15.88
Connection Pipe Diameter (Liquid / Gas)	Indoor	mm	25/32	25/32	25/32	25/32	25/32	25/32	25/32	25/32	
	Outdoor		25 (15)	25 (15)	30 (20)	30 (20)	30 (20)	50 (30)	50 (30)	50 (30)	50 (30)
Max Pipe Length (Pre-Charge)	Indoor	m	20	20	20	25	25	30	30	30	
	Outdoor		-15 to 46	-15 to 46	-15 to 46	-15 to 46	-15 to 46	-15 to 46	-15 to 46	-15 to 46	-15 to 46
Operation Range	Cooling	°CDB	-15 to 24	-15 to 24	-15 to 24	-15 to 24	-15 to 24	-15 to 24	-15 to 24	-15 to 24	-15 to 24
	Heating		R32 (675)	R32 (675)	R32 (675)	R32 (675)	R32 (675)	R32 (675)	R32 (675)	R32 (675)	R32 (675)
Refrigerant	Type (Global Warming Potential)	kg(CO2eq-1)	0.85 (0.574)	0.85 (0.574)	1.02 (0.689)	1.25 (0.844)	1.25 (0.844)	1.90(1.283)	1.90(1.283)	2.70(1.823)	2.70(1.823)
	Charge										

Optional parts

- Wired Remote Controller: UTY-RNRYZ3, UTY-RLRY, UTY-RVNYM, UTY-RNNYM
- Simple Remote Controller: UTY-RSRY, UTY-RHRY, UTY-RSNYM
- IR Receiver Kit: UTY-LBTYM
- Wireless LAN Interface: UTY-TFSXZ1
- Remote Sensor Unit: UTY-XSZX
- Long Life Filter: UTD-LFNA (ARXG36/45/54KHTAP), UTD-LFNB (ARXG18/24/30KHTAP), UTD-LFNC (ARXG12/14KHTAP)
- External Input and Output PCB (with bracket): UTY-XCSX + UTZ-GXNA
- External Connect Kit: UTY-XWZGX
- External Input and Output PCB BOX : UTZ-GXRA

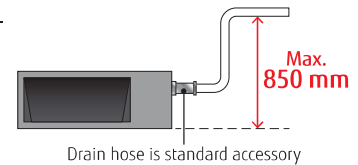

Dimensions

(Unit : mm)

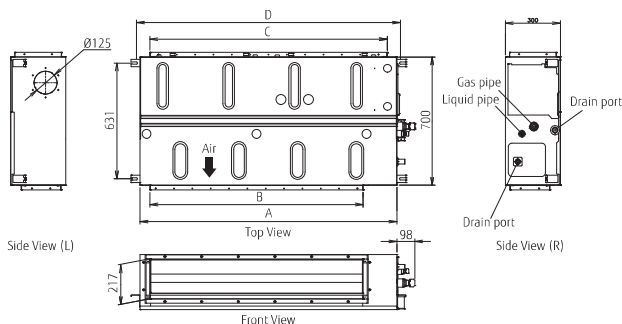

	ARXG12/14KHTAP	ARXG18/22/24/30KHTAP	ARXG36/45/54KHTAP
A	700	1,000	1,400
B	462	762	1,162
C	650	895	1,295
D	740	1,040	1,440

SPLIT

Medium Static Pressure Duct

Compact & Comfort

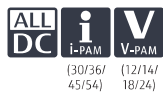

High Efficiency & Quiet operation

The combination of the V-shaped heat exchanger, air stabilizer, and the high efficient DC fan motor allowed high efficiency and quiet operation.

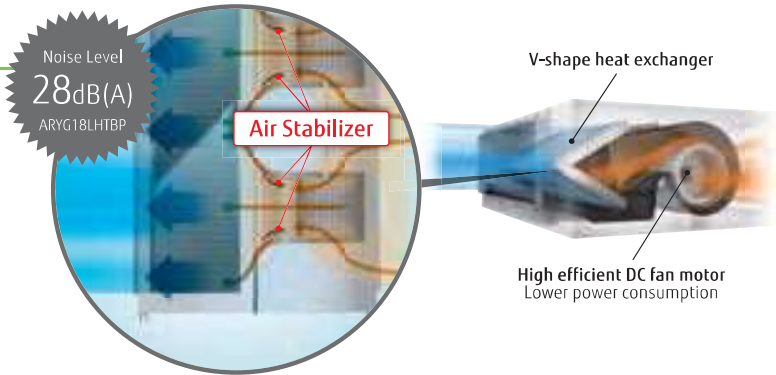

Automatic Airflow adjustment function

This unique and innovative function detects required air flow in each application case and automatically adjust the volume.



Improved installation flexibility

- Capable to be installed in various applications that requires static pressure of 30 Pa to 200 Pa*
 - Built-in drain pump, rises drain up to 850 mm
 - Unified depth throughout the range enables the selection of the capacity regardless of the additional space.
- (*: 12/14/18/24/30/36 models)

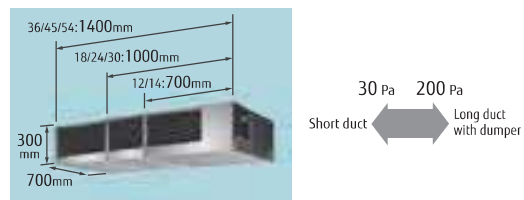

Improved service and maintenance

- Drain pump is easily detachable from the side
- Easy access to electrical box
- Error code can be checked more in detail from error history

Low ambient operation

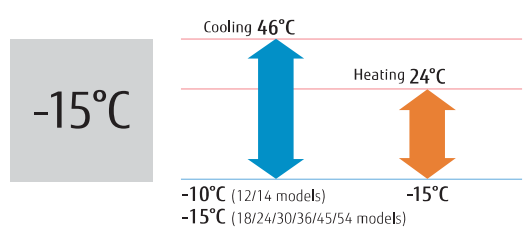

**Model: ARYG12LHTBP / ARYG14LHTBP / ARYG18LHTBP / ARYG24LHTBP
ARYG30LHTBP / ARYG36LHTBP / ARYG45LHTBP / ARYG54LHTBP**



ARYG12/14LHTBP



ARYG18/24/30LHTBP

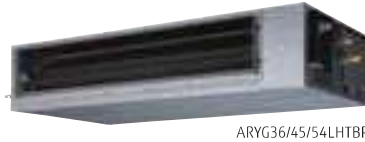

ARYG36/45/54LHTBP



Touch Panel Wired R.C.



For ARYG12/14LHTBP



For ARYG18/24LHTBP



For ARYG30/36LHTBP



For ARYG45/54LHTBP

Specifications

Model No.	Indoor unit		ARYG12LHTBP	ARYG14LHTBP	ARYG18LHTBP	ARYG24LHTBP	ARYG30LHTBP	ARYG36LHTBP	ARYG45LHTBP	ARYG54LHTBP
	Outdoor unit		AOYG12LBLA	AOYG14LBLA	AOYG18LBCA	AOYG24LBCA	AOYG30LBTB	AOYG36LBTB	AOYG45LBTB	AOYG54LBTB
Power Source			Single-phase, ~230V, 50Hz							
Capacity	Cooling	kW	3.5 (0.9-4.4)	4.3 (0.9-5.4)	5.2 (0.9-6.5)	6.8 (0.9-8.0)	8.5 (2.8-10.0)	9.4 (2.8-11.2)	12.1 (4.0-14.0)	13.4 (4.5-14.5)
	Heating		4.1 (0.9-5.7)	5.0 (0.9-6.5)	6.0 (0.9-7.5)	8.0 (0.9-9.1)	10.0 (2.7-11.2)	11.2 (2.7-12.7)	13.3 (4.2-16.2)	16.0 (4.7-16.5)
Input Power	Cooling/Heating		0.90/1.00	1.18/1.25	1.37/1.48	1.95/2.21	2.65/2.70	2.83/3.07	3.59/3.44	4.42/4.62
	EER	W/W	3.89	3.64	3.80	3.49	3.21	3.32	3.37	3.03
COP	Heating		4.10	4.00	4.05	3.62	3.70	3.65	3.87	3.46
Pdesign	Cooling/Heating(-10°C)		3.5/4.2	4.3/4.5	5.2/4.3	6.8/ 6.0	8.5/8.0	9.4/8.7	-	-
SEER	Cooling		6.20	6.10	7.15	6.50	5.95	5.81	-	-
SCOP	Heating (Average)		4.10	4.00	4.11	4.01	3.95	3.81	-	-
Energy Efficiency Class	Cooling		A++	A++	A++	A++	A+	A+	-	-
	Heating (Average)		A+	A+	A+	A+	A	A	-	-
Max. Operating Current	Cooling/Heating		8.0/10.5	9.5/13.0	10.0/13.5	13.5/18.5	17.0/17.0	20.0/20.0	22.5/22.5	23.5/23.5
Annual Energy Consumption	Cooling		198	247	255	366	500	566	-	-
	Heating		1,434	1,573	1,462	2,092	2,833	3,194	-	-
Moisture Removal			0.7	0.9	1.2	1.8	2.3	2.0	2.6	2.6
Sound Pressure Level	Indoor (Cooling)	H/M/L/Q	32/27/26/24	33/28/27/25	28/25/22/20	32/28/24/21	36/33/30/29	36/31/28/26	39/35/31/29	39/35/31/29
	Indoor (Heating)	H/M/L/Q	32/27/26/24	33/28/27/25	28/25/22/20	32/28/24/21	36/33/30/29	33/31/28/26	39/35/31/29	39/35/31/29
Sound Power Level	Outdoor(Cooling/Heating)	High	47/48	49/49	50/51	55/56	53/55	54/55	55/55	55/57
	Indoor(Cooling/Heating)	High	57/58	59/60	54/54	57/57	63/65	64/63	67/69	67/69
Airflow Rate	Indoor/Outdoor (Cooling)	High	850/1,780	950/1,910	1,050/1,900	1,360/2,460	1,700/3,600	2,050/2,800	2,550/6,750	2,550/6,750
	Indoor / Outdoor (Heating)	High	850/1,630	950/1,740	1,050/1,700	1,360/2,340	1,700/3,600	1,850/2,800	2,550/6,200	2,550/6,850
Static pressure range (Standard)			30 to 200 (35)	30 to 200 (35)	30 to 200 (35)	30 to 200 (35)	30 to 200 (47)	30 to 200 (47)	30 to 160 (60)	30 to 160 (60)
Net Dimensions H x W x D	Indoor	mm	300×700×700	300×700×700	300×1,000×700	300×1,000×700	300×1,000×700	300×1,400×700	300×1,400×700	300×1,400×700
	Outdoor	mm	578×790×300	578×790×300	620×790×290	620×790×290	830×900×330	830×900×330	1,290×900×330	1,290×900×330
Weight	Indoor	kg(lbs)	27 (59)	27 (59)	36 (79)	36 (79)	36 (79)	46 (101)	46 (101)	46 (101)
	Outdoor	kg(lbs)	40 (88)	40 (88)	41 (90)	41 (90)	61 (134)	61 (134)	86 (189)	86 (189)
Connection Pipe Diameter (Liquid / Gas)			6.35/9.52	6.35/12.70	6.35/12.70	6.35/15.88	9.52/15.88	9.52/15.88	9.52/15.88	9.52/15.88
Drain hose Diameter (I.D./O.D.)			25/32	25/32	25/32	25/32	25/32	25/32	25/32	25/32
Max Pipe Length (Pre-Charge)			25 (15)	25 (15)	30 (15)	30 (15)	50 (20)	50 (20)	50 (20)	50 (20)
Max Height Difference			15	15	20	20	30	30	30	30
Operation Range	Cooling		-10 to 46	-10 to 46	-15 to 46	-15 to 46	-15 to 46	-15 to 46	-15 to 46	-15 to 46
	Heating		-15 to 24	-15 to 24	-15 to 24	-15 to 24	-15 to 24	-15 to 24	-15 to 24	-15 to 24
Refrigerant	Type (Global Warming Potential)		R410A (2,088)	R410A (2,088)	R410A (2,088)	R410A (2,088)	R410A (2,088)	R410A (2,088)	R410A (2,088)	R410A (2,088)
	Charge		kg(CO2eq-T)	1.15 (2.4)	1.25 (2.6)	1.80 (3.8)	1.80 (3.8)	2.10 (4.4)	2.10 (4.4)	3.35 (7.0)

Optional parts

- Wired Remote Controller: UTY-RNRYZ3, UTY-RVNYM, UTY-RNNYM, UTY-RLRY
- Simple Remote Controller: UTY-RSNYM, UTY-RSRY, UTY-RHRY
- IR Receiver Unit: UTY-LBTYM
- Wireless LAN Interface: UTY-TFNXZ1
- External connect kit: UTY-XWZXZG
- Long life filter: UTD-LFNA (ARYG36/45/54LHTBP), UTD-LFNB (ARYG18/24/30LHTBP), UTD-LFNC (ARYG12/14LHTBP)
- Remote Sensor Unit: UTY-XSXZ
- External input and output PCB (with bracket): UTY-XCSX + UTZ-GXNA
- External Input and Output PCB BOX: UTZ-GXRA

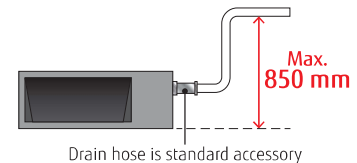

Drain hose is standard accessory

Dimensions

(Unit : mm)

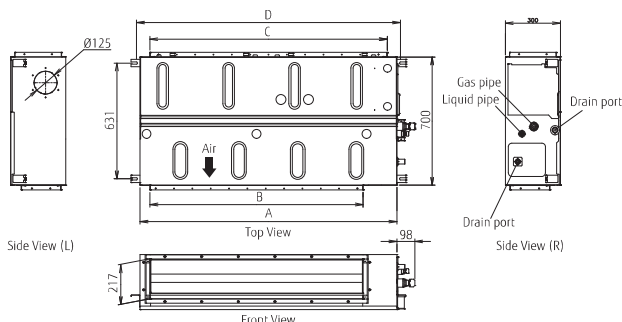

	ARYG12/14LHTBP	ARYG18/24/30LHTBP	ARYG36/45/54LHTBP
A	700	1,000	1,400
B	462	762	1,162
C	650	895	1,295
D	740	1,040	1,440

SPLIT

NEW

Medium Static Pressure Duct Standard



Slim & Compact design

Indoor Unit

The slim and compact design of the indoor unit, with the control box mounted on the side of the unit, allows installation in narrow spaces.

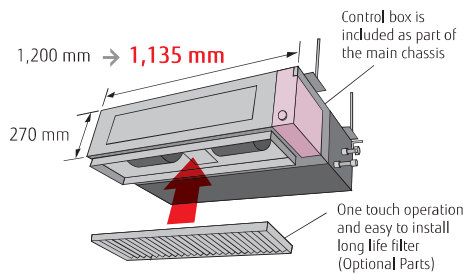

New Outdoor Unit

45 model outdoor unit was changed completely. Easier installation was realized by compact and lightweight outdoor unit.

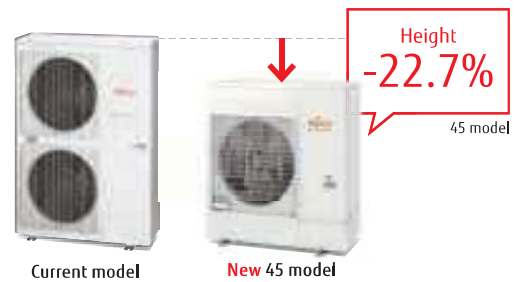

Easy maintenance

Structural improvement is attained by making the bottom panel two pieces, front and rear. The internal fan casing is also manufactured in two pieces, namely upper and lower. The maintenance of the motor and fan can be easily carried out by removing the rear panel and the lower part of the casing while leaving the main chassis installed.

See below for the case of rear suction type

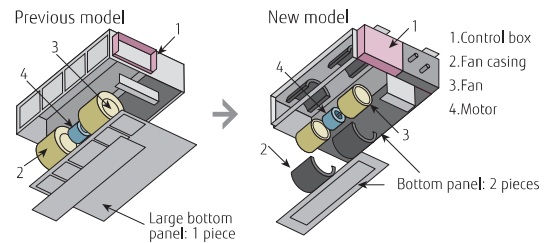

Two-direction drain piping

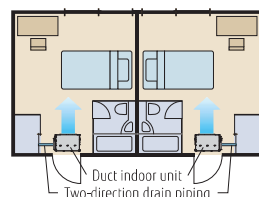

All class low ambient operation

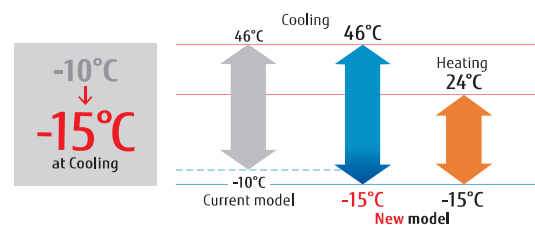



For ARXG22KMLA For ARXG24KMLA For ARXG30/36KMLA For ARXG45KMLA

Specifications

Model No.	Indoor unit		ARXG22KMLA	ARXG24KMLA	ARXG30KMLA	ARXG36KMLA	ARXG45KMLA
	Outdoor unit		AOYG22KBTB	AOYG24KBTB	AOYG30KBTB	AOYG36KBTB	AOYG45KBTB
Power Source	Single-phase, ~230V, 50Hz						
Capacity	Cooling	kW	6.0 (0.9-6.7)	6.8 (0.9-8.0)	8.5 (2.8-10.0)	9.5 (2.8-11.2)	12.1 (4.0-13.0)
	Heating		7.0 (0.9-8.0)	7.5 (0.9-9.1)	10.0 (2.7-11.2)	10.8 (2.7-12.7)	13.5 (4.2-15.2)
Input Power	Cooling/Heating	kW	1.78/1.87	2.14/1.97	2.65/2.63	2.97/2.88	4.22/3.84
EER	Cooling	W/W	3.37	3.18	3.21	3.20	2.87
	Heating		3.74	3.80	3.80	3.75	3.52
Pdesign	Cooling/Heating(-10°C)	kW	6.0/4.8	6.8/6.0	8.5/8.0	9.5/8.7	-
SEER	Cooling	W/W	6.10	6.20	6.23	6.10	-
	Heating		4.10	4.10	4.00	4.00	-
Energy Efficiency Class	Cooling		A++	A++	A++	A++	-
	Heating		A+	A+	A+	A+	-
Max. Operating Current	Cooling/Heating	A	12.6	13.6	22.6	22.6	28.5
Annual Energy Consumption	Cooling	kWh/a	344	384	477	545	-
	Heating		1,637	2,045	2,797	3,044	-
Moisture Removal		l/h	2.1	2.5	2.5	3.0	4.0
Sound Pressure Level	Indoor (Cooling)	H/M/L/Q	31/29/27/25	31/29/27/25	39/35/30/26	39/35/30/26	42/38/32/28
	Indoor (Heating)	H/M/L/Q	31/29/27/25	31/29/27/25	42/35/30/26	42/35/30/26	42/38/32/28
	Outdoor (Cooling/Heating)	High	51/51	53/54	53/55	55/55	57/57
Sound Power Level	Indoor (Cooling/Heating)	High	60/62	60/62	65/69	65/70	68/70
	Outdoor (Cooling/Heating)	High	63/63	65/66	68/69	70/70	71/71
Airflow Rate	Indoor / Outdoor (Cooling)	High	1,100/2,240	1,100/2,700	1,900/3,750	1,900/3,750	2,100/4,450
	Indoor / Outdoor (Heating)	High	1,100/1,960	1,100/2,700	2,100/3,750	2,100/3,750	2,100/4,450
Static pressure range (Standard)		Pa	30 to 150 (35)	30 to 150 (35)	30 to 150 (47)	30 to 150 (47)	30 to 150 (60)
Net Dimensions H x W x D	Indoor	mm	270x1,135x700	270x1,135x700	270x1,135x700	270x1,135x700	270x1,135x700
	Outdoor	mm	632x799x290	716x820x315	788x940x320	788x940x320	998x940x320
Weight	Indoor	kg(lbs)	35 (77)	35 (77)	38 (84)	38 (84)	39 (86)
	Outdoor	kg(lbs)	38 (84)	42 (93)	52 (115)	52 (115)	67 (148)
Connection Pipe Diameter (Liquid / Gas)		mm	6.35/12.70	6.35/12.70	9.52/15.88	9.52/15.88	9.52/15.88
Drain hose Diameter (I.D./O.D.)		mm	35.7/38.1	35.7/38.1	35.7/38.1	35.7/38.1	35.7/38.1
Max Pipe Length (Pre-Charge)		m	30 (20)	30 (20)	50 (30)	50 (30)	50 (30)
Max Height Difference			25	25	30	30	30
Operation Range	Cooling	°CDB	-15 to 46	-15 to 46	-15 to 46	-15 to 46	-15 to 46
	Heating		-15 to 24	-15 to 24	-15 to 24	-15 to 24	-15 to 24
Refrigerant	Type (Global Warming Potential)		R32 (675)	R32 (675)	R32 (675)	R32 (675)	R32 (675)
	Charge	kg(CO2eq-1)	1.25 (0.844)	1.25(0.844)	1.90(1.283)	1.90(1.283)	2.70(1.823)

Optional parts

- Wired Remote Controller: UTY-RNRYZ3, UTY-RLRY, UTY-RVNYM, UTY-RNNYM
- Simple Remote Controller: UTY-RSRY, UTY-RHRY, UTY-RSNYM
- IR Receiver Kit: UTY-LBTYM
- Flange (Round): UTD-RF204
- Flange (Square): UTD-SF045T
- Drain Pump Unit: UTZ-PX1NBA
- Wireless LAN Interface: UTY-TFSXZ1
- Remote Sensor Unit: UTY-XSZX
- Long Life Filter: UTD-LF25NA
- External Connect Kit: UTY-XWZXZG

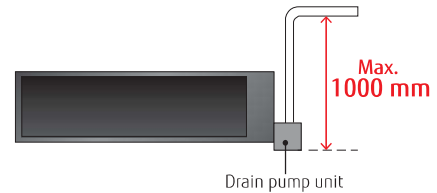

Dimensions

(Unit : mm)

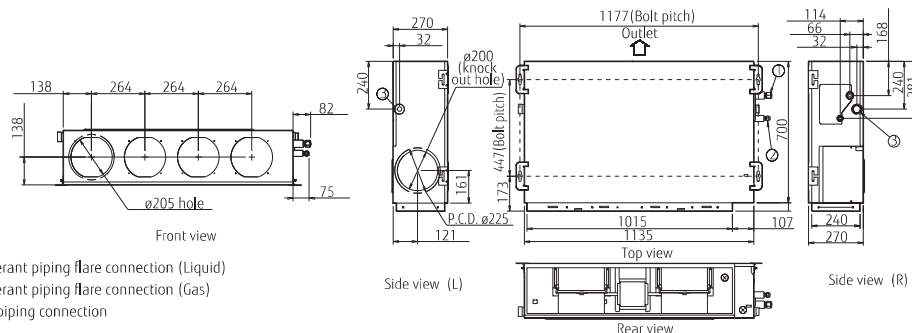

- ① Refrigerant piping flare connection (Liquid)
- ② Refrigerant piping flare connection (Gas)
- ③ Drain piping connection

SPLIT

Medium Static Pressure Duct Standard

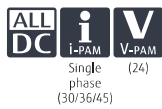

Slim & Compact design

In the case of bottom return air connection, not only does the indoor unit design allow for installation in a narrow ceiling space of up to 270 mm, further space savings have been achieved by mounting the control box internally inside the chassis.

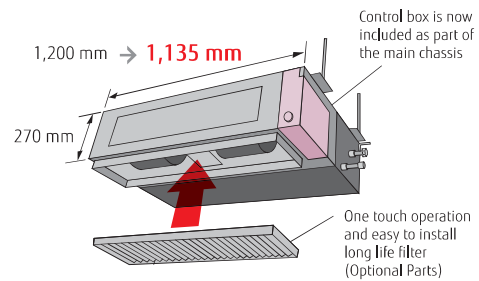

Easy maintenance

Structural improvement is attained by making the bottom panel two pieces, front and rear. The internal fan casing is also manufactured in two pieces, namely upper and lower. The maintenance of the motor and fan can be easily carried out by removing the rear panel and the lower part of the casing while leaving the main chassis installed.

See below for the case of rear suction type

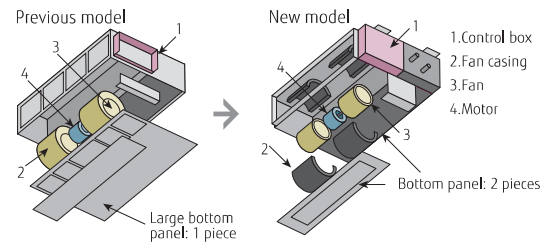

Two-direction drain piping

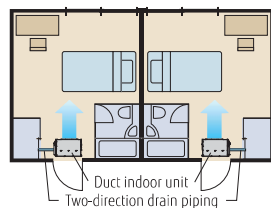

Low ambient operation

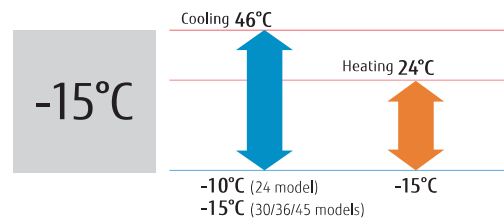

Model : ARYG24LMLA / ARYG30LMLE / ARYG36LMLE / ARYG45LMLA / ARYG36LMLA [3 phase] / ARYG45LMLA [3 phase]



Wired R.C.



For ARYG24LMLA



For ARYG30/36LMLE



For ARYG45LMLA (Single-phase)



For ARYG36/45LMLA

Specifications

Model No.	Indoor unit		ARYG24LMLA	ARYG30LMLE	ARYG36LMLE	ARYG45LMLA	ARYG45LMLA	ARYG36LMLA	ARYG45LMLA
	Outdoor unit		AOYG24LBCB	AOYG30LETL	AOYG36LETL	AOYG45LBTC	AOYG45LETL	AOYG36LATT	AOYG45LATT
Power Source	Single-phase, ~230V, 50Hz						3-phase, ~400V, 50Hz		
Capacity	Cooling	kW	6.8 (0.9-8.0)	8.5 (2.8-10.0)	9.4 (2.8-11.2)	12.1 (4.0-13.0)	12.1 (4.0-13.3)	10.0 (4.7-11.4)	12.5 (5.0-14.0)
	Heating		8.0 (0.9-9.1)	10.0 (2.7-11.2)	11.2 (2.7-12.7)	13.3 (4.2-15.2)	13.1 (4.2-15.5)	11.2 (5.0-14.0)	14.0 (5.4-16.2)
Input Power	Cooling/Heating	kW	2.21/2.26	2.65/2.68	2.96/3.10	4.29/3.84	3.77/3.68	2.84/2.87	3.89/3.88
EER	Cooling	W/W	3.08	3.21	3.18	2.82	3.21	3.52	3.21
COP	Heating	W/W	3.54	3.73	3.61	3.46	3.61	3.90	3.61
Pdesign	Cooling/Heating(-10°C)	kW	6.8/6.0	8.5/8.0	9.4/8.7	-	-	10.0/10.0	-
SEER	Cooling	W/W	6.20	5.90	5.70	-	-	5.80	-
SCOP	Heating	W/W	4.00	3.90	3.80	-	-	4.00	-
Energy Efficiency Class	Cooling		A++	A+	A+	-	-	A+	-
	Heating		A+	A	A	-	-	A+	-
Max. Operating Current	Cooling/Heating	A	14.7/15.7	17.0/17.0	18.5/20.0	23.5/23.5	21.0/21.0	8.5/8.5	9.5/9.5
Annual Energy Consumption	Cooling	kWh/a	384	504	576	-	-	603	-
	Heating	kWh/a	2,099	2,868	3,202	-	-	3,497	-
Moisture Removal		l/h	2.5	2.5	3.0	4.0	4.0	3.0	4.5
Sound Pressure Level	Indoor (Cooling)	H/M/L/Q	31/29/27/25	39/35/30/26	39/35/30/26	42/38/32/28	42/38/32/28	38/36/31/26	42/38/32/28
	Indoor (Heating)	H/M/L/Q	31/29/27/25	42/35/30/26	42/35/30/26	42/38/32/28	42/38/32/28	40/36/31/26	42/38/32/28
	Outdoor (Cooling/Heating)	High	53/54	53/55	54/55	58/58	55/55	51/53	54/54
Sound Power Level	Indoor (Cooling/Heating)	High	60/62	65/69	65/70	-	-	65/67	-
	Outdoor (Cooling/Heating)	High	66/66	68/69	69/70	-	-	67/69	-
Airflow Rate	Indoor / Outdoor (Cooling)	High	1,100/2,850	1,900/3,600	1,900/3,800	2,100/4,650	2,100/6,750	1,800/6,200	2,100/6,750
	Indoor / Outdoor (Heating)	High	1,100/2,700	2,100/3,600	2,100/3,800	2,100/4,650	2,100/6,850	1,850/6,200	2,100/6,200
Static pressure range (Standard)		Pa	30 to 150 (35)	30 to 150 (47)	30 to 150 (47)	30 to 150 (60)	30 to 150 (60)	30 to 150 (47)	30 to 150 (60)
Net Dimensions H x W x D	Indoor	mm	270×1,135×700	270×1,135×700	270×1,135×700	270×1,135×700	270×1,135×700	270×1,135×700	270×1,135×700
	Outdoor	mm	716×820×315	830×900×330	830×900×330	914×970×370	1,290×900×330	1,290×900×330	1,290×900×330
Weight	Indoor	kg(lbs)	38 (84)	40 (88)	40 (88)	40 (88)	40 (88)	40 (88)	40 (88)
	Outdoor	kg(lbs)	42 (93)	61 (134)	61 (134)	75 (165)	86 (190)	104 (229)	104 (229)
Connection Pipe Diameter (Liquid / Gas)		mm	6.35/15.88	9.52/15.88	9.52/15.88	9.52/15.88	9.52/15.88	9.52/15.88	9.52/15.88
Drain hose Diameter (I.D./O.D.)		mm	35.7/38.1	35.7/38.1	35.7/38.1	35.7/38.1	35.7/38.1	35.7/38.1	35.7/38.1
Max Pipe Length (Pre-Charge)		m	30 (15)	50 (20)	50 (20)	50 (20)	50 (20)	75 (30)	75 (30)
Max Height Difference		m	20	30	30	30	30	30	30
Operation Range	Cooling	°CDB	-10 to 46	-15 to 46	-15 to 46	-15 to 46	-15 to 46	-15 to 46	-15 to 46
	Heating	°CDB	-15 to 24	-15 to 24	-15 to 24	-15 to 24	-15 to 24	-15 to 24	-15 to 24
Refrigerant	Type (Global Warming Potential)		R410A (2,088)	R410A (2,088)	R410A (2,088)	R410A (2,088)	R410A (2,088)	R410A (2,088)	R410A (2,088)
	Charge	kg(CO2eq-T)	1.50 (3.1)	2.10 (4.4)	2.10 (4.4)	2.90 (6.1)	3.35 (7.0)	3.45 (7.2)	3.45 (7.2)

Optional parts

Wired Remote Controller: UTY-RNNYM, UTY-RVNYM
 Simple Remote Controller: UTY-RSNYM
 Flange (Round): UTD-RF204
 Flange (Square): UTD-SF045T
 Long Life Filter: UTD-LF25NA

Remote Sensor Unit: UTY-XSZX
 Drain Pump Unit: UTZ-PX1NBA
 IR Receiver Kit: UTY-LRHYM
 External connect kit: UTD-EC55A
 Wireless LAN Interface: UTY-TFNX21

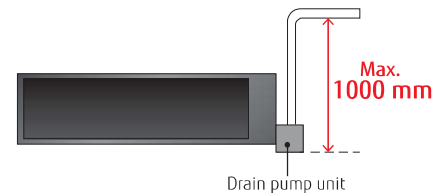

Dimensions

(Unit : mm)

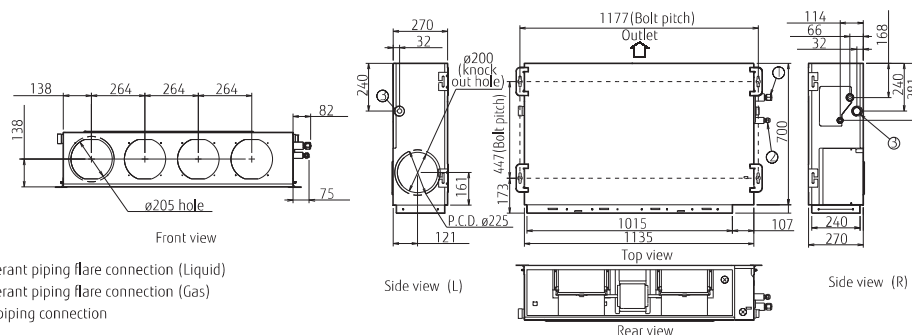

SPLIT

NEW

High Static Pressure Duct



Easy installation (Compact size & Lightweight)

A compact size and lightweight indoor unit & outdoor unit has been developed by reducing the basic chassis and the overall material weight.



Design also corresponding to high static pressure

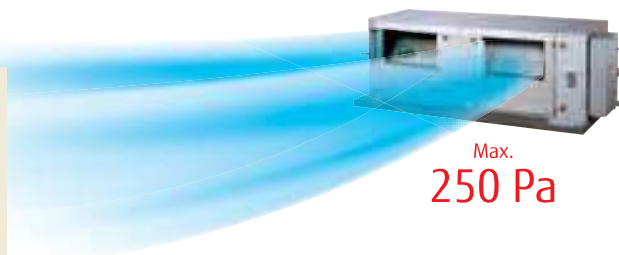
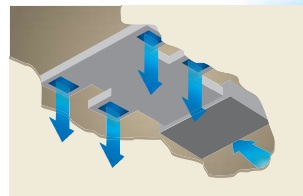

Low noise

Cutting off the corners has enabled less turbulent airflow. Low noise is realized by adopting a plastic case and a plastic fan.

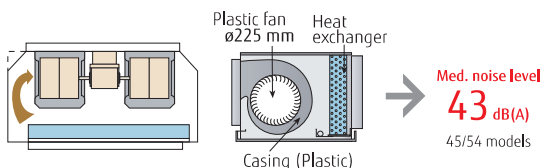

Low ambient operation

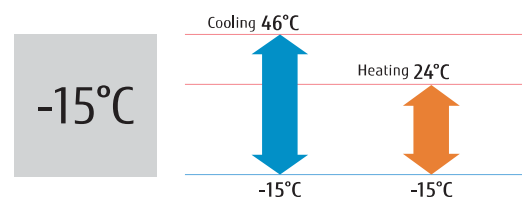

Model : ARXG45KHTA / ARXG54KHTA



Specifications

Model No.	Indoor unit		ARXG45KHTA	ARXG54KHTA
	Outdoor unit		AOYG45KBTB	AOYG54KBTB
Power Source	Single-phase, ~230V, 50Hz			
Capacity	Cooling	kW	12.1 (4.0-14.0)	13.4 (5.0-14.5)
	Heating		13.5 (5.0-16.2)	15.5 (5.5-18.0)
Input Power	Cooling/Heating		4.16/3.61	4.77/4.18
EER	Cooling		2.91	2.81
COP	Heating		3.74	3.71
Pdesign	Cooling/Heating(-10°C)		-	-
SEER	Cooling		-	-
SCOP	Heating		-	-
Energy Efficiency Class	Cooling		-	-
	Heating		-	-
Max. Operating Current	Cooling/Heating		28.5	28.5
Annual Energy Consumption	Cooling		-	-
	Heating		-	-
Moisture Removal			1.5	2.0
Sound Pressure Level	Indoor (Cooling)	H/M/L	47/43/40	47/43/40
	Indoor (Heating)	H/M/L	47/43/40	47/43/40
	Outdoor (Cooling/Heating)	High	57/57	57/59
Sound Power Level	Indoor (Cooling/Heating)	High	75/74	75/74
	Outdoor (Cooling/Heating)	High	71/71	73/73
Airflow Rate	Indoor / Outdoor (Cooling)	High	3,350/4,450	3,350/4,450
	Indoor / Outdoor (Heating)	High	3,350/4,450	3,350/4,450
Static pressure range (Standard)			100 to 250 (100)	100 to 250 (100)
Net Dimensions H x W x D	Indoor	mm	400x1,050x500	400x1,050x500
	Outdoor	mm	46 (101)	46 (101)
Weight	Indoor	kg(lbs)	998x940x320	998x940x320
	Outdoor	kg(lbs)	67 (148)	67 (148)
Connection Pipe Diameter (Liquid / Gas)			9.52/15.88	9.52/15.88
Drain hose Diameter (I.D./O.D.)			23.4/25.4	23.4/25.4
Max Pipe Length (Pre-Charge)			50 (30)	50 (30)
Max Height Difference			30	30
Operation Range	Cooling		-15 to 46	-15 to 46
	Heating		-15 to 24	-15 to 24
Refrigerant	Type (Global Warming Potential)		R32 (675)	R32 (675)
	Charge	kg(CO2eq-T)	2.70(1.823)	2.70(1.823)

Optional parts

- Wired Remote Controller: UTY-RVNYM, UTY-RNNYM
- Simple Remote Controller: UTY-RSNYM
- Wireless LAN Interface: UTY-TFNXZ1
- Remote Sensor Unit: UTY-XSZX
- Long Life Filter: UTD-LF60KA
- External Connect Kit: UTD-ECS5A

Dimensions

(Unit : mm)

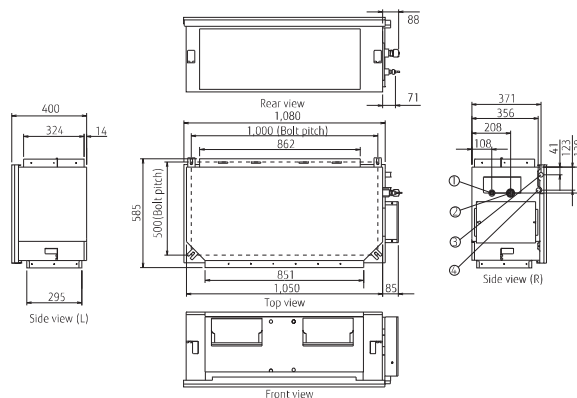

- ① Refrigerant piping flare connection (Liquid)
- ② Refrigerant piping flare connection (Gas)
- ③ Drain piping connection (Safety drain pan)
- ④ Drain piping connection (Main drain pan)

SPLIT

High Static Pressure Duct



High energy efficiency

Significantly greater efficiency is realized by using all DC inverter technology. (60 model)

Design also corresponding to high static pressure

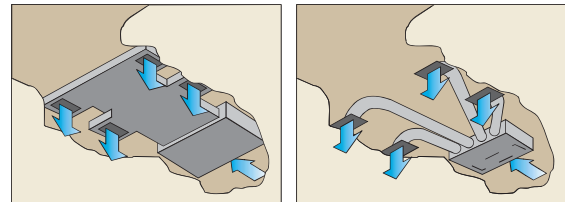
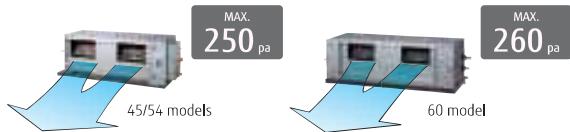

Easy installation (Compact size & Lightweight)

A compact size and lightweight indoor unit has been developed by reducing the basic chassis and the overall material weight.

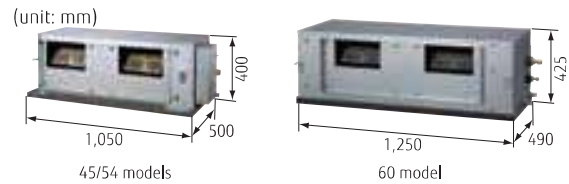

Low noise

Cutting off the corners has enabled less turbulent airflow. Low noise is realized by adopting a plastic case and a plastic fan.

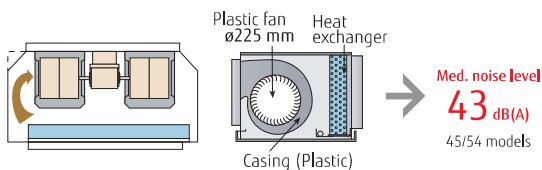

Low ambient operation

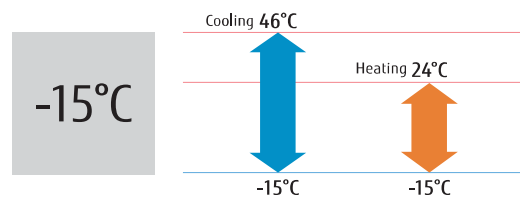

**Model : ARYG45LHTA / ARYG54LHTA /
ARYG45LHTA [3 phase] / ARYG54LHTA [3 phase] / ARYG60LHTA [3 phase]**



Wired R.C.



Specifications

Model No.	Indoor unit		ARYG45LHTA	ARYG54LHTA	ARYG45LHTA	ARYG54LHTA	ARYG60LHTA
	Outdoor unit		AOYG45LETL	AOYG54LETL	AOYG45LATT	AOYG54LATT	AOYG60LATT
Power Source			Single-phase, ~230V, 50Hz		3-phase, ~400V, 50Hz		
Capacity	Cooling	kW	12.5 (4.5-14.0)	13.4 (5.0-14.5)	12.5 (5.0-14.0)	14.0 (5.4-16.0)	15.0 (6.2-17.5)
	Heating		14.0 (5.0-16.2)	16.0 (5.5-18.0)	14.0 (5.4-16.2)	16.0 (5.8-18.0)	18.0 (6.2-18.0)
Input Power	Cooling/Heating	kW	4.30/3.80	4.77/4.69	4.06/3.67	4.65/4.37	4.70/5.15
EER	Cooling	W/W	2.91	2.81	3.08	3.01	3.19
	Heating		3.68	3.41	3.81	3.66	3.50
Max. Operating Current	Cooling/Heating	A	22.5/22.5	23.5/23.5	11.0/11.0	12.0/12.0	12.5/12.5
Moisture Removal		l/h	1.5	2.0	1.5	2.5	2.0
Sound Pressure	Indoor (Cooling)	H/M/L/Q	47/43/40/-	47/43/40/-	47/43/40/-	47/43/40/-	45/40/36/-
	Indoor (Heating)	H/M/L/Q	47/43/40/-	47/43/40/-	47/43/40/-	47/43/40/-	45/40/36/-
	Outdoor(Cooling/Heating)	High	55/55	55/57	54/54	55/56	56/58
Airflow Rate	Indoor / Outdoor (Cooling)	High	3,350/6,750	3,350/6,750	3,350/6,750	3,350/6,900	3,550/6,900
	Indoor / Outdoor (Heating)	High	3,350/6,200	3,350/6,850	3,350/6,200	3,350/6,900	3,550/7,300
Static pressure range (Standard)		Pa	100 to 250 (100)	100 to 250 (100)	100 to 250 (100)	100 to 250 (100)	60 to 260 (60)
Net Dimensions H x W x D	Indoor	mm	400×1,050×500	400×1,050×500	400×1,050×500	400×1,050×500	425×1,250×490
	Outdoor	mm	1,290×900×330	1,290×900×330	1,290×900×330	1,290×900×330	1,290×900×330
Weight	Indoor	kg(lbs)	46 (101)	46 (101)	46 (101)	46 (101)	54 (119)
	Outdoor	kg(lbs)	86 (189)	86 (189)	104 (229)	104 (229)	104 (229)
Connection Pipe Diameter (Liquid / Gas)		mm	9.52/15.88	9.52/15.88	9.52/15.88	9.52/15.88	9.52/15.88
Drain hose Diameter (I.D./O.D.)		mm	23.4/25.4	23.4/25.4	23.4/25.4	23.4/25.4	23.4/25.4
Max Pipe Length (Pre-Charge)		m	50 (20)	50 (20)	75 (30)	75 (30)	75 (30)
Max Height Difference			30	30	30	30	30
Operation Range	Cooling	°CDB	-15 to 46	-15 to 46	-15 to 46	-15 to 46	-15 to 46
	Heating		-15 to 24	-15 to 24	-15 to 24	-15 to 24	-15 to 24
Refrigerant	Type (Global Warming Potential)		R410A (2,088)	R410A (2,088)	R410A (2,088)	R410A (2,088)	R410A (2,088)
	Charge	kg(CO2eq-T)	3.35 (7.0)	3.35 (7.0)	3.45 (7.2)	3.45 (7.2)	3.45 (7.2)

Optional parts

Wired Remote Controller: UTY-RNNYM, UTY-RVNYM
 Simple Remote Controller: UTY-RSNYM
 Long-Life Filter: UTD-LF60KA (ARYG45/54LHTA)
 Remote Sensor Unit: UTY-XSZX
 IR Receiver Kit: UTY-LRHYM(ARYG60LHTA)
 External connect kit: UTD-ECS5A
 Wireless LAN Interface: UTY-TFSXZ1

Dimensions

(Unit : mm)

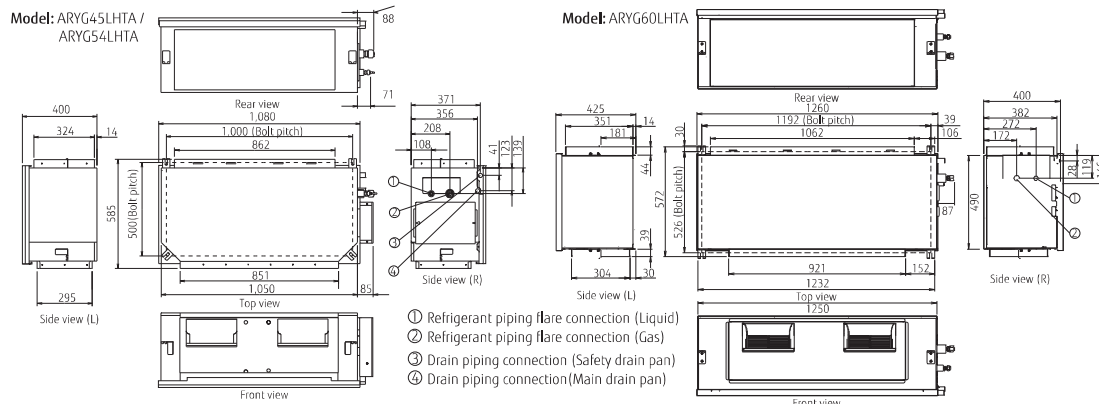

Big Duct



Separation is possible by lightweight compact design

The indoor unit can be separated into fan unit and heat-exchanger unit to assist the installation works.

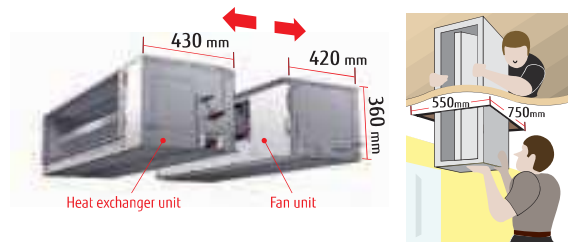

Automatic Airflow adjustment function

This function can set the optimum airflow automatically, so installation time is shortened drastically.



Quiet operation

The combination of the V-shaped heat exchanger, air stabilizer, and the high efficient DC fan motor allowed quiet operation despite of the small structural design.

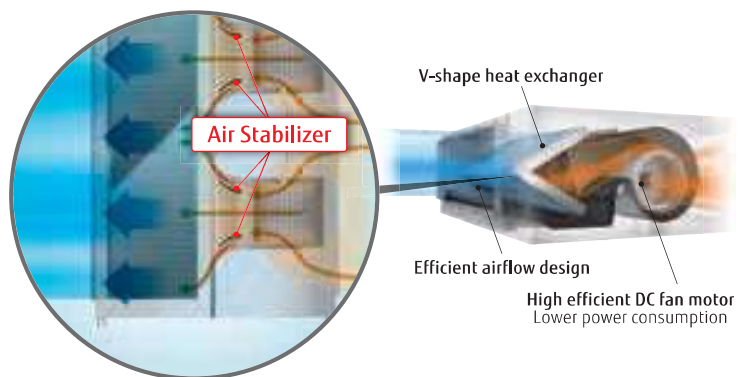

Model : ARYG72LHTA / ARYG90LHTA



Wired R.C.



Specifications

Model No.	Indoor unit		ARYG72LHTA	ARYG90LHTA
	Outdoor unit		AOYG72LRLA	AOYG90LRLA
Power Source	Indoor		Single-phase, ~230V, 50Hz	
	Outdoor		3-phase, ~400V, 50Hz	
Capacity	Cooling	kW	19.0 (8.4-20.9)	22.0 (10.3-24.2)
	Heating		22.4 (7.2-24.6)	27.0 (8.5-29.7)
Input Power	Cooling/Heating	kW	6.46 / 6.59	7.77 / 8.18
EER	Cooling	W/W	2.94	2.83
COP	Heating		3.40	3.30
Max. Operating Current	Indoor(Cooling/Heating)		4.6/4.6	6.0/6.0
	Outdoor(Cooling/Heating)		13.3/13.3	14.6/14.6
Moisture Removal			l/h	4.5 / 6.0
Sound Pressure	Indoor (Cooling)	H/M/L/Q	46/43/41/39	47/44/42/40
	Indoor (Heating)	H/M/L/Q	46/43/41/39	47/44/42/40
	Outdoor(Cooling/Heating)	High	55/55	55/57
Airflow Rate	Indoor / Outdoor (Cooling)		High	4,300/8,400
	Indoor / Outdoor (Heating)		High	4,300/8,400
Static pressure range (Standard)			Pa	50 to 150 (72)
Net Dimensions H x W x D	Indoor		mm	360×1,400×850
	Outdoor		mm	1,428×1,080×480
Weight	Indoor		kg(lbs)	69 (152)
	Outdoor		kg(lbs)	165 (363)
Connection Pipe Diameter (Liquid / Gas)			mm	12.7/25.4
Drain Hose Diameter (I.D./O.D.)			mm	24.4/32.0
Max Pipe Length (Pre-Charge)			m	100 (30)
Height Difference				30
Operation Range	Cooling		°CDB	-15 to 46
	Heating			-20 to 24
Refrigerant	Type (Global Warming Potential)			R410A (2.088)
	Charge		kg(CO2eq-T)	5.6 (11.7)

Optional parts

- Wired Remote Controller: UTY-RNRYZ3, UTY-RLRY, UTY-RVNYM, UTY-RNNYM
- Simple Remote Controller: UTY-RSRY, UTY-RHRY, UTY-RSNYN
- IR Receiver Unit: UTY-LBTYM, UTY-LRHYM
- Remote Sensor Unit: UTY-XSZX
- External Connect Kit: UTY-XWZXZG
- External Input and Output PCB: UTY-XCSX
- Drain Pump Unit: UTZ-PXINAB
- Long Life filter: UTD-LFKA
- Wireless LAN Interface: UTY-TFSXZ1

Dimensions

(Unit : mm)

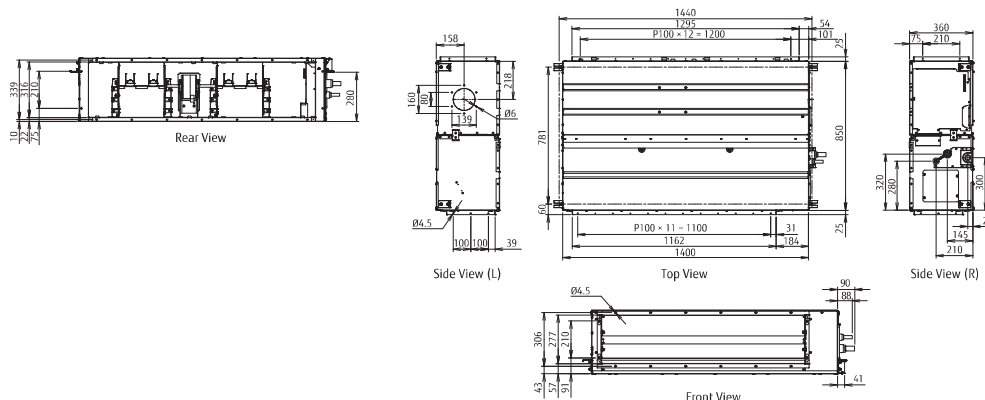

SPLIT

Floor

Compact & Comfort



2-Fan & Wide airflow

Individual vertical airflow by 2-fan can control the whole room comfortably.



Flexible & easy installation

Due to compact and whole surface suction method model, floor, concealed, half concealed, or wall mounted installation can be available to match the room layout.

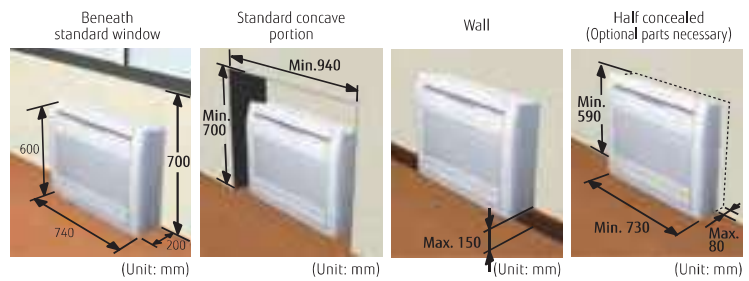

Flexible piping connection 6 direction of drain & piping

Drain hose and piping can be drawn flexibly in the right, left, side, and down directions

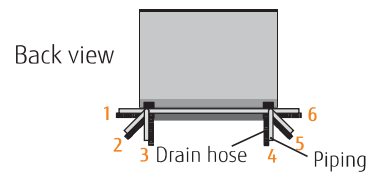

10°C HEAT Operation

The room temperature can be set to go no lower than 10°C, thus ensuring that the room does not get too cold when not occupied

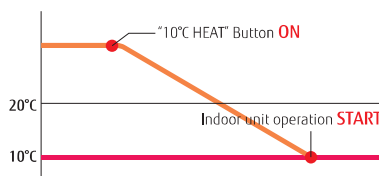

Low ambient operation

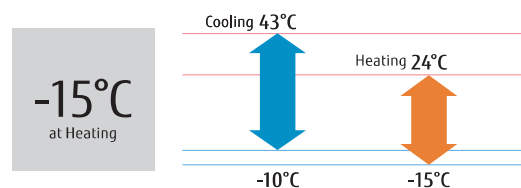

Model: AGYG09LVCA / AGYG12LVCA / AGYG14LVCA



Wireless R.C.



For AGYG09/12LVCA



For AGYG14LVCA

Specifications

Model No.	Indoor unit		AGYG09LVCA	AGYG12LVCA	AGYG14LVCA
	Outdoor unit		AOYG09LVCA	AOYG12LVCA	AOYG14LVCA
Power Source			Single-phase, ~230V, 50Hz		
Capacity	Cooling	kW	2.6 (0.9-3.5)	3.5 (0.9-4.0)	4.2 (0.9-5.0)
	Heating		3.5 (0.9-4.95)	4.5 (0.9-5.3)	5.2 (0.9-6.3)
Input Power	Cooling/Heating	kW	0.53/0.79	0.94/1.19	1.14/1.44
EER	Cooling	W/W	4.91	3.72	3.68
	Heating		4.43	3.78	3.61
Pdesign	Cooling/Heating(-10°C)	kW	2.6/2.9	3.5/3.8	4.2/4.7
SEER	Cooling	W/W	7.00	6.50	6.40
	Heating (Average)		4.20	4.00	4.00
Energy Efficiency Class	Cooling		A++	A++	A++
	Heating (Average)		A+	A+	A+
Max. Operating Current	Cooling/Heating	A	7.0/10.0	7.0/10.0	9.0/13.5
Annual Energy Consumption	Cooling	kWh/a	130	188	230
	Heating		967	1,330	1,645
Moisture Removal		l/h	1.3	1.8	2.1
Sound Pressure Level	Indoor (Cooling)	H/M/L/Q	40/35/29/22	40/35/29/22	44/38/31/22
	Indoor (Heating)	H/M/L/Q	40/35/29/22	40/35/29/22	43/37/29/22
Sound Power Level	Outdoor(Cooling/Heating)	High	47/48	48/49	50/50
	Indoor(Cooling/Heating)	High	55/56	55/56	58/58
Airflow Rate	Outdoor(Cooling/Heating)	High	64/65	64/65	65/66
	Indoor / Outdoor (Cooling)	High	570/1,680	570/1,680	650/1,910
Net Dimensions H x W x D	Indoor / Outdoor (Heating)	High	600/1,490	600/1,680	650/1,750
	Indoor	mm	600×740×200	600×740×200	600×740×200
Weight	Outdoor	mm	540×790×290	540×790×290	578×790×300
	Indoor	kg(lbs)	14 (31)	14 (31)	14 (31)
Connection Pipe Diameter (Liquid / Gas)	Outdoor	kg(lbs)	36 (79)	36 (79)	40 (88)
	Indoor	mm	6.35/9.52	6.35/9.52	6.35/12.70
Drain hose Diameter (I.D./O.D.)		mm	13.8/15.8 to 16.7	13.8/15.8 to 16.7	13.8/15.8 to 16.7
Max Pipe Length (Pre-Charge)		m	20 (15)	20 (15)	20 (15)
Max Height Difference			15	15	15
Operation Range	Cooling	°CDB	-10 to 43	-10 to 43	-10 to 43
	Heating		-15 to 24	-15 to 24	-15 to 24
Refrigerant	Type (Global Warming Potential)		R410A (2,088)	R410A (2,088)	R410A (2,088)
	Charge	kg(CO2eq-T)	1.05 (2.2)	1.05 (2.2)	1.15 (2.4)

Optional parts

- Wired Remote Controller: UTY-RNNYM, UTY-RVNYM
- Simple Remote Controller: UTY-RSNYM
- Half Concealed Kit: UTR-STA
- Wireless LAN Interface: UTY-TFNXZ1
- External Connect Kit: UTY-XWZX

Dimensions

(Unit : mm)

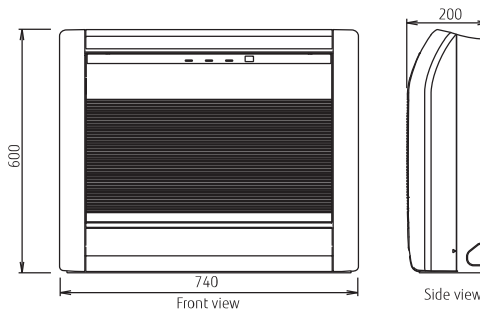

SPLIT

Floor/Ceiling

Comfort & Dual Design



Flexible installation

Example for floor installation
Floor console



Example for ceiling installation
Under ceiling



Double auto swing

A combination of right/left and up/down directional swing allows 3-dimensional air direction control

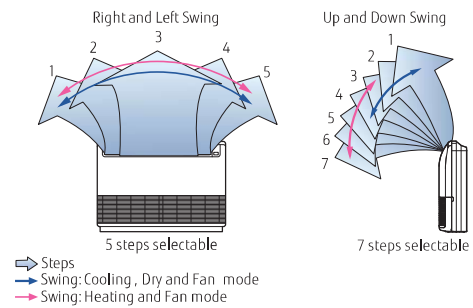

High power DC fan motor

- High power
- Wide rotation range
- High efficiency

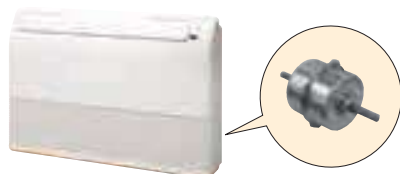

Low ambient operation

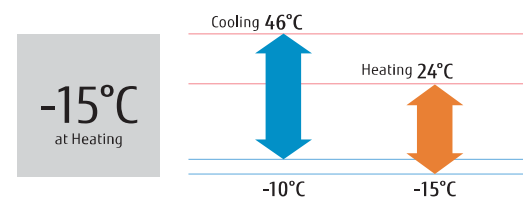

Model : ABYG18LVTB / ABYG24LVTA



Wireless R.C.



For ABYG18LVTB



For ABYG24LVTA

Specifications

Model No.	Indoor unit		ABYG18LVTB	ABYG24LVTA
	Outdoor unit		AOYG18LBCB	AOYG24LBCB
Power Source			Single-phase, ~230V, 50Hz	
Capacity	Cooling	kW	5.2 (0.9-5.9)	6.8 (0.9-8.0)
	Heating		6.0 (0.9-7.5)	8.0 (0.9-9.1)
Input Power	Cooling/Heating		1.62/1.66	2.21/2.26
EER	Cooling	W/W	3.21	3.08
	Heating		3.61	3.54
Pdesign	Cooling/Heating(-10°C)		5.2/5.2	6.8/6.0
SEER	Cooling		6.10	5.60
SCOP	Heating (Average)		4.00	3.90
	Cooling		A++	A+
Energy Efficiency Class	Heating (Average)		A+	A
	Cooling/Heating		11.5/13.5	14.7/15.7
Max. Operating Current	Cooling/Heating			
	Cooling		298	425
Annual Energy Consumption	Cooling		1,818	2,153
	Heating			
Moisture Removal			2.0	2.7
Sound Pressure Level	Indoor (Cooling)	H/M/L/Q	43/40/34/31	48/44/40/35
	Indoor (Heating)	H/M/L/Q	43/40/34/31	48/44/40/35
Sound Power Level	Outdoor(Cooling/Heating)	High	50/50	53/54
	Indoor(Cooling/Heating)	High	57/57	61/61
Airflow Rate	Outdoor(Cooling/Heating)	High	62/65	66/66
	Indoor / Outdoor (Cooling)	High	780/2,380	980/2,850
Net Dimensions H x W x D	Indoor / Outdoor (Heating)	High	780/2,080	980/2,700
	Indoor	mm	199×990×655	199×990×655
Weight	Outdoor	mm	632×799×290	716×820×315
	Indoor	kg(lbs)	27 (59)	27 (59)
Connection Pipe Diameter (Liquid / Gas)	Outdoor	kg(lbs)	36 (79)	42 (93)
	Indoor	mm	6.35/12.70	6.35/15.88
Drain hose Diameter (I.D./O.D.)			25/32	25/32
Max Pipe Length (Pre-Charge)			25 (15)	30 (15)
Max Height Difference			15	20
Operation Range	Cooling	°CDB	-10 to 46	-10 to 46
	Heating		-15 to 24	-15 to 24
Refrigerant	Type (Global Warming Potential)		R410A (2.088)	R410A (2.088)
	Charge	kg(CO2eq-T)	1.20 (2.5)	1.50 (3.1)

Optional parts

- Wired Remote Controller: UTY-RNNYM, UTY-RVNYM
- Simple Remote Controller: UTY-RSNYM
- Wireless LAN Interface: UTY-TFNXZ1
- External Connect Kit: UTY-XWZX

Dimensions

(Unit : mm)

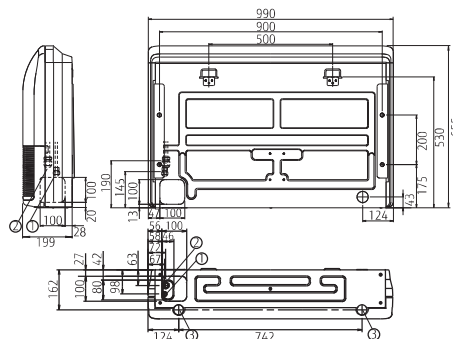

- ① Refrigerant piping flare connection (Liquid)
- ② Refrigerant piping flare connection (Gas)
- ③ Drain piping connection

SPLIT

Ceiling

Comfort for Large Room



Flexible installation

Various installations are possible to match the room layout.

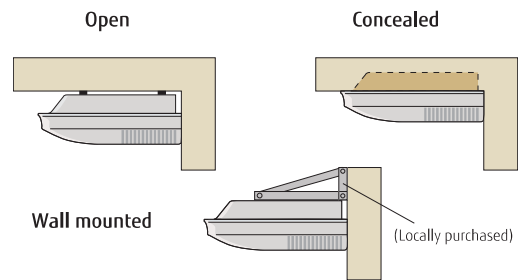

Multi auto swing

A combination of right/left and up/down directional swing allows 3-dimensional air direction control.

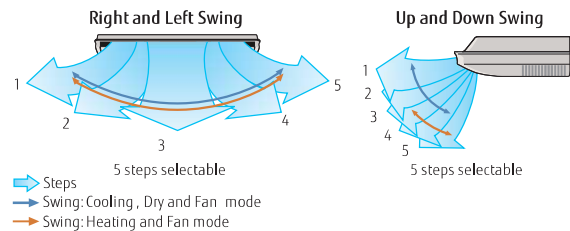

Fresh air intake

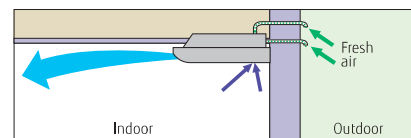

Low ambient operation

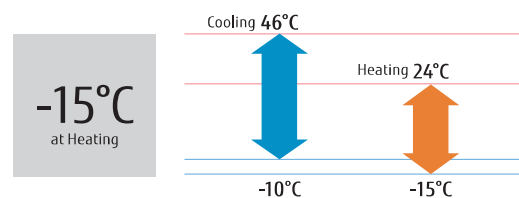

**Model : ABYG30LRTE / ABYG36LRTE / ABYG45LRTA /
ABYG36LRTA [3 phase] / ABYG45LRTA [3 phase] / ABYG54LRTA [3 phase]**



Specifications

Model No.	Indoor unit		ABYG30LRTE	ABYG36LRTE	ABYG45LRTA	ABYG45LRTA	ABYG36LRTA	ABYG45LRTA	ABYG54LRTA
	Outdoor unit		AOYG30LETL	AOYG36LETL	AOYG45LBTC	AOYG45LETL	AOYG36LATT	AOYG45LATT	AOYG54LATT
Power Source			Single-phase, ~230V, 50Hz				3-phase, ~400V, 50Hz		
Capacity	Cooling	kW	8.5 (2.8-10.0)	9.4 (2.8-11.2)	12.1 (4.0-13.0)	12.1 (4.0-13.3)	10.0 (4.7-11.4)	12.5 (5.0-14.0)	14.0 (5.4-16.0)
	Heating		10.0 (2.7-11.2)	11.2 (2.7-12.7)	13.3 (4.2-15.2)	13.3 (4.2-15.5)	11.2 (5.0-14.0)	14.0 (5.4-16.2)	16.0 (5.8-18.0)
Input Power	Cooling/Heating	kW	2.65/2.77	2.93/3.02	4.29/3.84	3.77/3.68	2.84/2.87	3.89/3.88	4.65/4.67
EER	Cooling	W/W	3.21	3.21	2.82	3.21	3.52	3.21	3.01
COP	Heating		3.61	3.71	3.46	3.61	3.90	3.61	3.43
Pdesign	Cooling/Heating(-10°C)	kW	8.5/8.0	9.4/8.7	-	-	10.0/10.0	-	-
SEER	Cooling	W/W	6.10	6.00	-	-	6.10	-	-
SCOP	Heating		4.20	4.10	-	-	4.10	-	-
Energy Efficiency Class	Cooling	A	A++	A+	-	-	A++	-	-
	Heating		A+	A+	-	-	A+	-	-
Max. Operating Current	Cooling/Heating	kWh/a	17.0/17.0	18.5/20.0	23.5/23.5	20.5/20.5	7.9/7.9	8.9/8.9	9.9/9.9
	Cooling		487	548	-	-	573	-	-
Annual Energy Consumption	Heating	2,662	2,965	-	-	3,414	-	-	
	Moisture Removal	l/h	2.5	3.0	4.0	4.0	3.0	4.5	5.0
Sound Pressure Level	Indoor (Cooling)	H/M/L/Q	45/43/37/32	47/43/37/32	49/45/39/34	49/45/39/34	47/43/37/32	49/45/39/34	51/48/42/38
	Indoor (Heating)		45/43/37/32	47/43/37/32	49/45/39/34	49/45/39/34	47/43/37/32	49/45/39/34	51/48/42/38
Sound Power Level	Outdoor (Cooling/Heating)	High	53/55	54/55	58/58	55/55	51/53	54/54	55/56
	Indoor (Cooling/Heating)		High	57/60	60/61	-	-	61/61	-
Airflow Rate	Outdoor (Cooling/Heating)	High	68/69	69/70	-	-	67/69	-	-
	Indoor / Outdoor (Cooling)		m³/h	1,660/3,600	1,900/3,800	2,100/4,650	2,100/6,750	1,900/6,200	2,100/6,750
Net Dimensions H x W x D	Indoor / Outdoor (Heating)	High		1,660/3,600	1,900/3,800	2,100/4,650	2,100/6,200	1,900/6,200	2,100/6,200
	Indoor		mm	240×1,660×700	240×1,660×700	240×1,660×700	240×1,660×700	240×1,660×700	240×1,660×700
Weight	Outdoor	mm	830×900×330	830×900×330	914×970×370	1,290×900×330	1,290×900×330	1,290×900×330	1,290×900×330
	Indoor	kg(lbs)	46 (101)	46 (101)	46 (101)	46 (101)	46 (101)	46 (101)	48 (106)
Connection Pipe Diameter (Liquid / Gas)	Outdoor	kg(lbs)	61 (134)	61 (134)	75 (165)	86 (189)	104 (229)	104 (229)	104 (229)
	Indoor	mm	9.52/15.88	9.52/15.88	9.52/15.88	9.52/15.88	9.52/15.88	9.52/15.88	9.52/15.88
Drain port Diameter (I.D./O.D.)		mm	22.0/25.6	22.0/25.6	21.5/26.0	21.5/26.0	21.5/26.0	21.5/26.0	21.5/26.0
Max Pipe Length (Pre-Charge)		m	50 (20)	50 (20)	50 (20)	50 (20)	75 (30)	75 (30)	75 (30)
Max Height Difference			30	30	30	30	30	30	30
Operation Range	Cooling	°CDB	-15 to 46	-15 to 46	-15 to 46	-15 to 46	-15 to 46	-15 to 46	-15 to 46
	Heating		-15 to 24	-15 to 24	-15 to 24	-15 to 24	-15 to 24	-15 to 24	-15 to 24
Refrigerant	Type (Global Warming Potential)		R410A (2,088)	R410A (2,088)	R410A (2,088)	R410A (2,088)	R410A (2,088)	R410A (2,088)	R410A (2,088)
	Charge	kg(CO2eq-T)	2.10 (4.4)	2.10 (4.4)	2.90 (6.1)	3.35 (7.0)	3.45 (7.2)	3.45 (7.2)	3.45 (7.2)

Optional parts

- Wired Remote Controller: UTY-RNNYM, UTY-RVNYM
- Simple Remote Controller: UTY-RSNNYM
- Drain Pump Unit: UTR-DPB24T
- Flange (Round): UTD-RF204
- Wireless LAN Interface: UTY-TFNX21
- External Connect Kit: UTD-ECS5A, UTY-XWZX

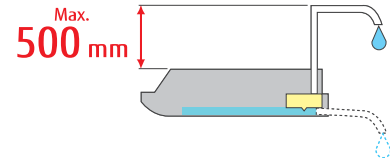

Dimensions

(Unit : mm)

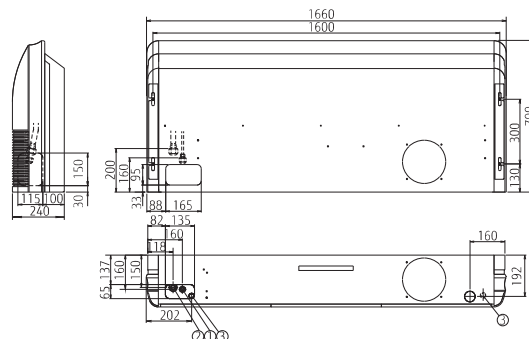

Feature Summary

Type		Wall Mounted											
Series	Flagship Range	Designer Range	Standard Range		ECO Range		Designer Range		Standard Range		ECO Range		
Model No.	ASYG 12KXCA	ASYG 07/09/12/14 KGTB	ASYG 07/09/12/14 KMTB	ASYG 18/24KMTA	ASYG 07/09/12 KPCA	ASYG 18/24KLCA	ASYG 09/12LTCA	ASYG 07/09/12/14 LUCA	ASYG 07/09/12/14 LMCE	ASYG 18/30LFCA, ASYG 24LFCC	ASYG 30/36LMTA	ASYG 07/09/12 LLCE	
Energy Saving Function	Dual side fans	●											
	Save human sensor	●	●					●				●	
	Save & Stop human sensor												
	Economy mode	●	●	●	●	●	●	●	●	●	●	●	
	Room temperature set point limitation		○	○	○			○	○	○	○	○	
	Set temperature auto return		○	○	○			○	○	○	○	○	
Comfortable Function	Powerful heating							●					
	Power diffuser	●								●	●		
	Server room operation										●		
	Powerful mode	●	●	●	●	●	●	●	●	●	●	●	
	10°C HEAT operation	●	●	●	●			●	●	●	●	●	
	Low noise mode	●	●	●	●			●	●	●		●	
	Auto-changeover	●	●	●	●	●	●	●	●	●	●	●	
	Up/down swing flaps		●	●	●	●	●	●	●	●			●
	Double swing automatic	●			●						●	●	
	Automatic fan speed	●	●	●	●	●	●	●	●	●	●	●	
	Auto restart	●	●	●	●	●	●	●	●	●	●	●	
	Connectable fresh air duct												
	Fresh air intake												
	Connectable distributing duct												
	Individual airflow direction control												
	Convenient Function	Auto off timer		○	○	○			○	○	○	○	
Sleep timer		●	●	●	●	●	●	●	●	●	●	●	
Program timer		●	●	●	●	●	●	●	●	●	●	●	
Weekly timer			●	○	●			●	●		●		
Weekly + setback timer			○	○	○			○	○	○	○		
Filter sign			●	●	●	●	●	●	●	●	●	●	
External error output			○	○	○			○	○	○	○		
External ON/OFF input			○	○	○			○	○	○	○		
Clean Function	Wireless LAN control	●	○	○	○	○		○	○	○	○		
	Plasma air clean	●											
	Filter auto clean	●											
	Ion deodorization filter		○	○	●			●	●	●	●		
	Apple-catechin filter		○	○	●			●	●	●	●		
	Long life filter												
Installation	Washable panel				●	●	●		●	●		●	
	Automatic airflow adjustment												
	Drain pump as standard												
	Blue fin									● (30)	●		

Light Commercial & Residential MULTI SPLIT

- 120 Multi Split Overview
- 122 Outdoor Units Lineup
- 124 2-8 Rooms Connectable Indoor Units
- 126 Simultaneous Multi Connectable Indoor Units
- 168 Feature Explanation & Summary



Refrigerant type R32 models

2 Rooms Multi

128 **New** 2 Rooms Multi

Simultaneous Multi

136 **New** Simultaneous Multi Twin/Triple

2 Rooms Multi Split Indoor Units

142 **New** 2 Rooms Multi Indoor Units Specifications

146 **New** 2 Rooms Multi Combination Table



Refrigerant type R410A models

2 - 8 Rooms Multi

130 2 & 3-4 Rooms Multi

132 5-6 Rooms Multi

134 8 Rooms Multi

Simultaneous Multi

138 Simultaneous Multi Twin/Triple

140 Simultaneous Multi Twin/Triple/Double Twin

2 - 8 Rooms Multi Split Indoor Units

144 2-8 Rooms Indoor Units Specifications

147 2-8 Rooms Multi Combination Table

**Control several indoor units with one outdoor unit.
Build the system you desire.**

If you want to keep a large floor as well as many rooms comfortable, we recommend to use our Multi Splits to build a compact system using just one outdoor unit. Choose from a large lineup of indoor units, which match up well to your rooms. You can mix and match them as you like. Build the system that is just right for you.

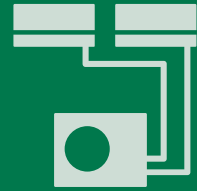

Multi Split Overview

Space-saving multi outdoor units can connect up to 8 indoor units in multiple rooms. New refrigerant R32 models are additionally added. Multi split type can be introduced in various situations like in homes, in offices and stores to provide environment-friendly comfort.



NEW

2 Rooms Multi



14 class

18 class

2-8 Rooms Multi

2-8 Rooms Multi type units are recommended for situations that require air conditioning in multiple rooms such as in family house or offices. Between 2 to 8 indoor units can be connected and individually operated. A variation of individual and central remote controller are available for operation control, time scheduling of each room and energy savings. Due to space - saving outdoor unit enables installation on balcony or under a waist-high window.



2 & 3-4 Rooms Multi



2 Rooms 14/18 class

5-6 Rooms Multi



36/45 class



3 Rooms 18/24 class

8 Rooms Multi



4 Rooms 30 class



45 class



NEW

Twin/Triple



Twin 36 class
(Single phase)

Twin/Triple 45/54 class
(Single phase)



Twin/Triple

Twin/Triple/ Double Twin



36/45/54 class
(Single phase/3 phase)















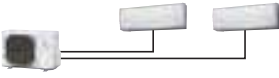



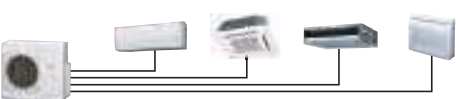

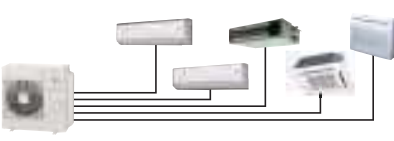

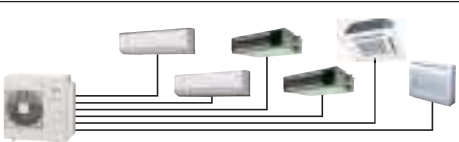

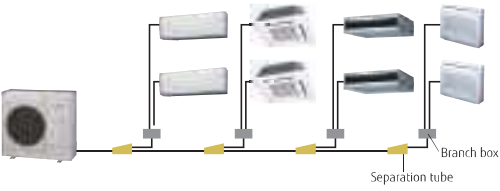

72/90 class
(3 phase)

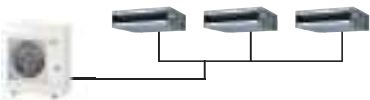
Simultaneous Multi

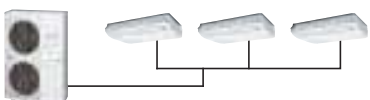
Simultaneous Multi type is recommended for situations where multiple indoor units need to be operated simultaneously such as for a small building, for small office building entrance, meeting room, educational facility hall, and other large spaces. Up to 4 indoor units can be operated simultaneously. This type is suitable for office spaces with large areas and properties with unusual floor layout.

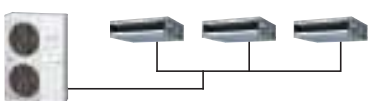
Outdoor Units Lineup

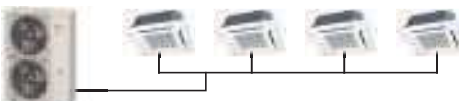
				Class	14	18
				Cooling rated capacity(kW)	4	5
2 & 3-4 Rooms Multi	2 Rooms Multi Up to 2 units				AOYG14KBTA2	AOYG18KBTA2
					AOYG14LAC2	AOYG18LAC2
	3 Rooms Multi Up to 3 units					
	4 Rooms Multi Up to 4 units					
5-6 Rooms Multi	5 Rooms Multi Up to 5 units					
	6 Rooms Multi Up to 6 units					
8 Rooms Multi Up to 8 units						
Simultaneous Multi	Twin Single phase					
	Twin/Triple Single phase					
	Twin/Triple Single phase					
	Twin/Triple 3 phase					
	Twin/Triple/Double Twin 3 phase					

Note: 1. 2 Rooms Multi: Connectable indoor units are 2 units.

AOYG14KBTA2: Total capacity of indoor units connected must be between 4.0 kW and 6.0 kW.
 AOYG18KBTA2: Total capacity of indoor units connected must be between 4.0 kW and 7.5 kW.
 AOYG14LAC2: Total capacity of indoor units connected must be between 4.0 kW and 6.0 kW.
 AOYG18LAC2: Total capacity of indoor units connected must be between 4.0 kW and 7.0 kW.

2. 3 Rooms Multi: Connectable indoor units are 2 to 3 units.

AOYG18LAT3: Total capacity of indoor units connected must be between 4.0 kW and 8.5 kW.
 AOYG24LAT3: Total capacity of indoor units connected must be between 4.0 kW and 10.5 kW.

3. 4 Rooms Multi: Connectable indoor units are 3 to 4 units.

AOYG30LAT4: Total capacity of indoor units connected must be between 7.5 kW and 14.0 kW.

	18	24	30	36	45		54	72	90
	5.4	6.8	8	10	12.5	14	14	19	22
	AOYG18LAT3*	AOYG24LAT3*							
			AOYG30LAT4*						
				AOYG36LBLA5*					
					AOYG45LBLA6*				
						AOYG45LBT8*			
				AOYG36KBTB	AOYG45KBTB				
							AOYG54KBTB		
				AOYG36LBTB	AOYG45LBTB*1		AOYG54LBTB*2		
				AOYG36LATT	AOYG45LATT		AOYG54LATT		
								AOYG72LRLA	AOYG90LRLA

4.5 Rooms Multi: Connectable indoor units are 2 to 5 units

AOYG36LBLA5: Total capacity of indoor units connected must be between 7.5 kW and 15.5 kW.

5.6 Rooms Multi: Connectable indoor units are 2 to 6 units

AOYG45LBLA6 Total capacity of indoor units connected must be between 9.5 kW and 18.0 kW.

6.8 Rooms Multi: Connectable indoor units are 2 to 8 units

AOYG45LBT8: Total capacity of indoor units connected must be between 11.0 kW and 18.0 kW.



FUJITSU GENERAL (Euro) GmbH participates in the ECP programme for AIR CONDITIONERS.



Check ongoing validity of certificate:

www.eurovent-certification.com

* Models so marked are not ECC certified.

2 – 8 Rooms Connectable Indoor Units



Type	2 Rooms	
Model name	AOYG14KBTA2	AOYG18KBTA2
Multi Split Outdoor Unit		
Capacity (kW)	Cooling	4.0
	Heating	4.4

Indoor Unit	BTU	kW Class	AOYG14KBTA2	AOYG18KBTA2
 ASYG07/09/12/14KGTB	7,000	2.0	●	●
	9,000	2.5	●	●
	12,000	3.5	●	●
	14,000	4.0	—	●
 AUXG07/09/12/14KVL A	7,000	2.0	●	●
	9,000	2.5	●	●
	12,000	3.5	●	●
	14,000	4.0	—	●
 ARXG07/09/12/14KSLAP	7,000	2.0	●	●
	9,000	2.5	●	●
	12,000	3.5	●	●
	14,000	4.0	—	●
 ARXG07/09/12/14KLLAP	7,000	2.0	●	●
	9,000	2.5	●	●
	12,000	3.5	●	●
	14,000	4.0	—	●



Type	2 Rooms		3 Rooms		4 Rooms	5 Rooms	6 Rooms	8 Rooms	
Model name	AOYG 14LAC2	AOYG 18LAC2	AOYG 18LAT3	AOY G24LAT3	AOYG30LAT4	AOYG36LBLA5	AOYG45LBLA6	AOYG45LBT8	
Multi Split Outdoor Unit									
Capacity (kW)	Cooling	4.0	5.0	5.4	6.8	8.0	10.0	12.5	14.0
	Heating	4.4	5.6	6.8	8.0	9.6	12.0	13.5	16.0

Indoor Unit	BTU	kW Class								
 ASYG07/09/12/14LMCE	7,000	2.0	●	●	●	●	●	●	●	●
	9,000	2.5	●	●	●	●	●	●	●	●
 ASYG07/09/12/14LUCA	12,000	3.5	●	●	●	●	●	●	●	●
	14,000	4.0	—	●	●	●	●	●	●	●
 ASYG18/24LF	18,000	5.0	—	—	—	●	●	●	●	●
	24,000	7.0	—	—	—	—	●	—	●	●
 AGYG09/12/14LV	9,000	2.5	—	●	●	●	●	●	●	●
	12,000	3.5	—	●	●	●	●	●	●	●
	14,000	4.0	—	—	●	●	●	●	●	●
 AUYG07/09/12/14/18LV	7,000	2.0	—	●	●	●	●	●	●	●
	9,000	2.5	—	●	●	●	●	●	●	●
	12,000	3.5	—	●	●	●	●	●	●	●
	14,000	4.0	—	—	●	●	●	●	●	●
	18,000	5.0	—	—	—	●	●	●	●	●
 ABYG14/18LV	14,000	4.0	—	—	●	●	●	●	●	●
	18,000	5.0	—	—	—	●	●	●	●	●
 ARYG07/09/12/14/18LSLAP	7,000	2.0	—	●	●	●	●	●	●	—
	9,000	2.5	—	●	●	●	●	●	●	—
	12,000	3.5	—	●	●	●	●	●	●	—
	14,000	4.0	—	—	●	●	●	●	●	—
	18,000	5.0	—	—	—	●	●	●	●	—
 ARYG07/09/12/14/18LL	7,000	2.0	—	●	●	●	●	●	●	●
	9,000	2.5	—	●	●	●	●	●	●	●
	12,000	3.5	—	●	●	●	●	●	●	●
	14,000	4.0	—	—	●	●	●	●	●	●
	18,000	5.0	—	—	—	●	●	●	●	●

Simultaneous Multi Connectable Indoor Units



Type	4HP	5HP	6HP	
Model name	AOYG36KBTB	AOYG45KBTB	AOYG54KBTB	
Simultaneous Multi Outdoor Unit				
Capacity (kW)	Cooling	9.5	12.1	13.4
	Heating	10.8	13.5	15.5

Indoor Unit	BTU	kW Class	Twin			Triple
 AUXG18/22/24KVLA	18,000	5.0	● ×2	—	—	● ×3
	22,000	6.5	—	● ×2	—	—
	24,000	7.0	—	—	● ×2	—
 ARXG18KLLAP	18,000	5.0	● ×2	—	—	● ×3
	22,000	6.5	—	● ×2	—	—
 ARXG22/24KMLA	24,000	7.0	—	—	● ×2	—
	Separation tube			UTP-SX236A (18/22/24)		



Type	4HP		5HP		6HP		8HP	10HP
Model name	AOYG36LBTB	AOYG36LATT	AOYG45LBTB	AOYG45LATT	AOYG54LBTB	AOYG54LATT	AOYG72LRLA	AOYG90LRLA
Simultaneous Multi Outdoor Unit								
Capacity (kW)	Cooling	10.0	12.1	12.5	13.3	14.0	19.0	22.0
	Heating	11.2	14.0	14.0	15.0	16.0	22.4	27.0

Indoor Unit	BTU	kW Class	Twin		Triple	Twin	Triple	Double Twin	Twin	Triple	Double Twin	
 AUYG18/22/24LV	18,000	5.0	● ×2	-	-	● ×3	-	-	● ×4	-	-	
	22,000	6.5	-	● ×2	-	-	-	-	-	-	● ×4	
	24,000	7.0	-	-	● ×2	-	-	● ×3	-	-	-	
 AUYG30/36/45LR	30,000	8.8	-	-	-	-	-	-	-	● ×3	-	
	36,000	10.6	-	-	-	-	● ×2	-	-	-	-	
	45,000	12.5	-	-	-	-	-	-	● ×2	-	-	
 ARYG18LL	18,000	5.0	● ×2	-	-	● ×3	-	-	● ×4	-	-	
 ARYG22/24/30/36/45LM	22,000	6.5	-	● ×2	-	-	-	-	-	-	● ×4	
	24,000	7.0	-	-	● ×2	-	-	● ×3	-	-	-	
	30,000	8.8	-	-	-	-	-	-	-	● ×3	-	
	36,000	10.6	-	-	-	-	● ×2	-	-	-	-	
	45,000	12.5	-	-	-	-	-	-	● ×2	-	-	
 ABYG18/22/24LV	18,000	5.0	● ×2	-	-	● ×3	-	-	● ×4	-	-	
	22,000	6.5	-	● ×2	-	-	-	-	-	-	● ×4	
	24,000	7.0	-	-	● ×2	-	-	● ×3	-	-	-	
 ABYG30/36/45LR	30,000	8.8	-	-	-	-	-	-	-	● ×3	-	
	36,000	10.6	-	-	-	-	● ×2	-	-	-	-	
	45,000	12.5	-	-	-	-	-	-	● ×2	-	-	
Separation tube			UTP-SX236A ×1	UTP-SX254A ×1	UTP-SX254 ×1	UTP-SX354A ×1	UTP-SX272A ×1	UTP-SX372A ×1	UTP-SX272A ×1, UTP-SX236A ×2	UTP-SX272A ×1	UTP-SX372A ×1	UTP-SX272A ×1, UTP-SX254A ×2

MULTI SPLIT

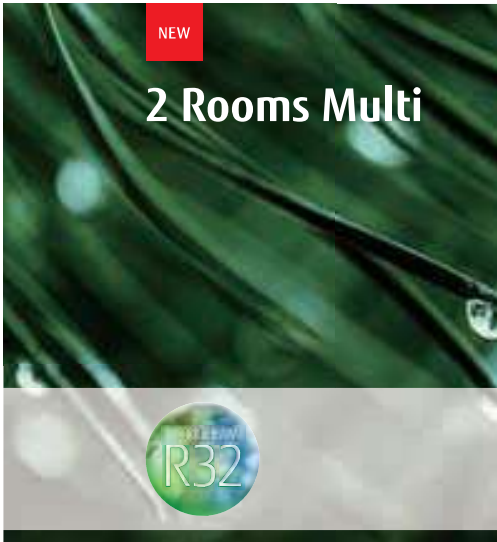

High energy saving

DC technology is used for compressor, indoor / outdoor fan motor and inverter controlling.



SEER ^{*1} 8.7 SCOP 4.7

*1: 14 model

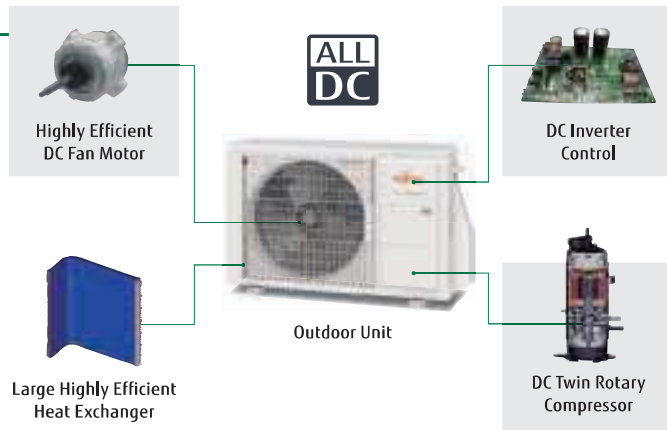

Wide range of indoor units with various models

4 types / 16 models are lined up in the capacity range from 2.0 kW to 4.0 kW class. Wide range of requirements can be realized from in private homes, large shops and hotels.



Models equipped with the New R32 Refrigerant

Wall mounted type with sophisticated design



Middle and small capacity models are available. This makes it easier to install at small spaces.



Mini Duct



Compact Cassette



Slim Duct

2 Rooms: AOYG14KBTA2 / AOYG18KBTA2



14

18

Specifications

Model No.			AOYG14KBTA2	AOYG18KBTA2
Power Source			Single-phase, ~230V, 50Hz	
Rated Capacity (min-max)	Cooling	kW	4.0 (1.4-4.6)	5.0 (1.7-5.8)
	Heating		4.4 (1.1-5.5)	5.6 (1.8-7.0)
EER	Cooling	W/W	4.12	4.03
	Heating		4.63	4.59
Sound Pressure Level (High)	Cooling	dB(A)	47	47
	Heating		49	50
Sound Power Level (High)	Cooling	dB(A)	60	60
	Heating		62	62
Airflow Rate	Cooling/Heating	m ³ /h	1,670/1,670	1,960/2,020
Net Dimensions H × W × D			mm	542×799×290
Weight			kg(lbs)	33 (73)
Connection Pipe Diameter	Liquid	mm	6.35×2	6.35×2
	Gas		9.53 × 2	9.53 × 2
Max. Pipe Length			Total / Each	30 / 20
Max. Height Difference	Between Outdoor Unit and Each Indoor Units.		m	15
	Between Indoor Units.		m	10
Operation Range	Cooling	°CDB	-10 to 46	-10 to 46
	Heating		-15 to 24	-15 to 24
Refrigerant	Type (Global Warming Potential)		R32 (675)	R32 (675)
	Charge		kg(CO ₂ eq-t)	1.02 (0.689)

MULTI SPLIT

Dimensions

(Unit : mm)

AOYG14KBTA2

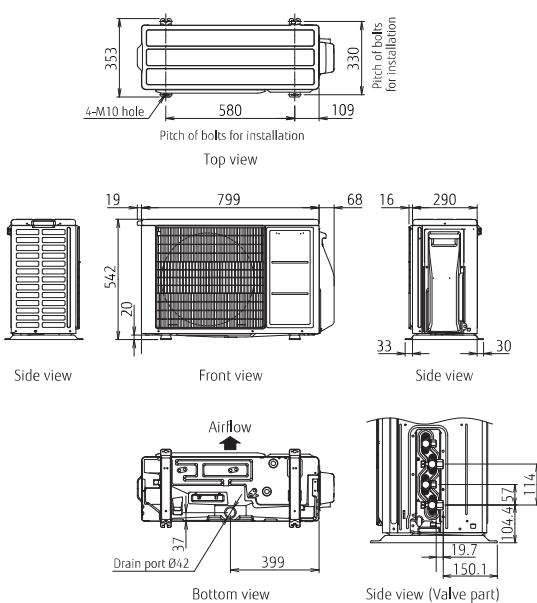

AOYG18KBTA2

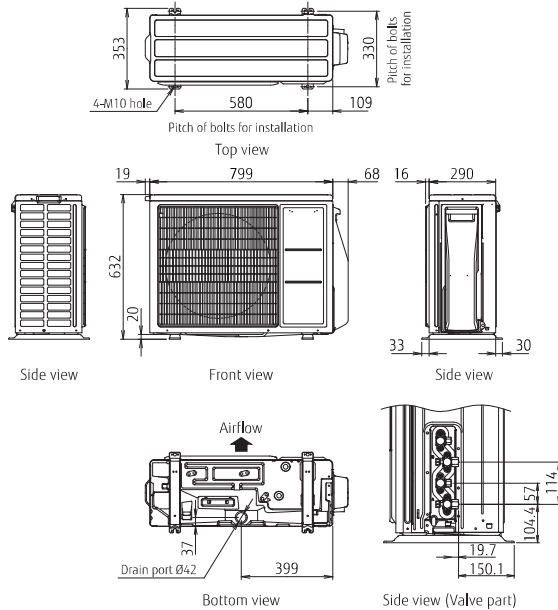

MULTI SPLIT



2 & 3-4 Rooms
Multi



Wide range of indoor units with various models

4 types / 16 models are lined up in the capacity range from 2.0 kW to 4.0 kW class. Wide range of requirements can be realized from in private homes, large shops and hotels.

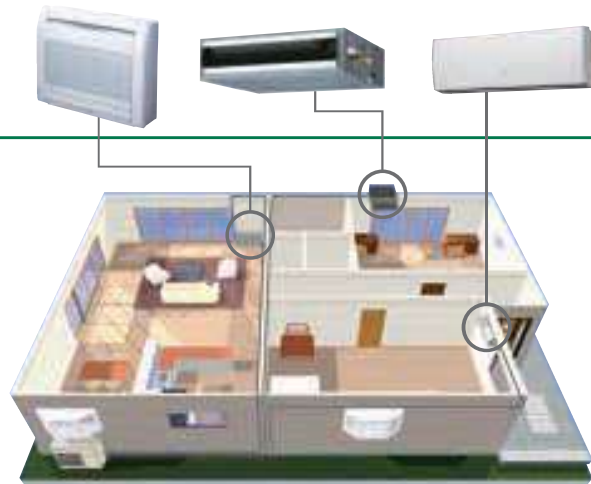

Space-saving installation

Multiple indoor units can be connected to 1 outdoor unit, and long piping connection is also possible. Compared with single type, the outdoor unit can be installed in various places to realize the space-saving installation.

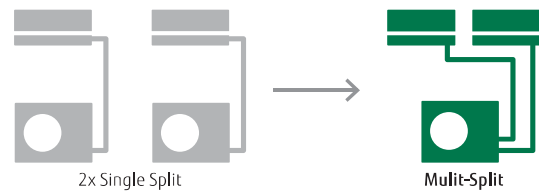

Flexible installation

Up to max. piping length of 70 m (AOYG30LAT4), max. height difference of 15 m can be supported. Multi type can be installed in large-size residence or buildings with multiple floors.

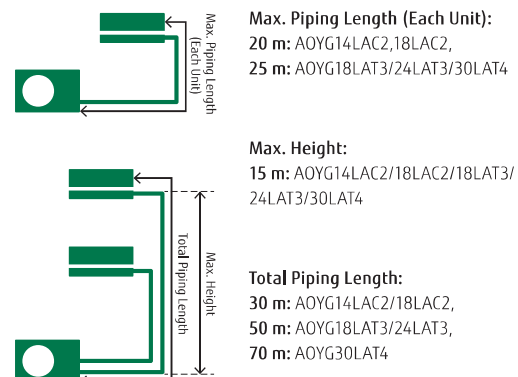

2 Rooms: AOYG14LAC2 / AOYG18LAC2
 3 Rooms: AOYG18LAT3 / AOYG24LAT3
 4 Rooms: AOYG30LAT4



Specifications (2 Rooms, 3 Rooms, 4 Rooms)

Model No.			AOYG14LAC2	AOYG18LAC2	AOYG18LAT3	AOYG24LAT3	AOYG30LAT4
Power Source			Single-phase, ~230V, 50Hz				
Rated Capacity (min-max)	Cooling	kW	4.0 (1.4-4.4)	5.0 (1.7-5.6)	5.4 (1.8-6.8)	6.8 (1.8-8.5)	8.0 (3.5-10.1)
	Heating		4.4 (1.1-5.4)	5.6 (1.8-6.1)	6.8 (2.0-8.0)	8.0 (2.0-9.2)	9.6 (3.7-12.0)
EER	Cooling	W/W	3.67	3.21	4.00	3.51	3.60
	Heating		4.27	3.97	4.20	4.00	4.00
Sound Pressure Level (High)	Cooling	dB(A)	47	50	46	48	50
	Heating		49	51	47	49	51
Sound Power Level (High)	Cooling	dB(A)	61	63	65	68	68
	Heating		63	64	67	70	70
Airflow Rate	Cooling/Heating	m ³ /h	1,850/1,850	2,050/2,050	3,050/2,750	3,300/3,300	3,500/3,300
Net Dimensions H × W × D			540×790×290	540×790×290	700×900×330	700×900×330	830×900×330
Weight			37 (82)	38 (84)	55 (121)	55 (121)	68 (150)
Connection Pipe Diameter	Liquid	mm	6.35×2	6.35×2	6.35×3	6.35×3	6.35×4 (*6.35×3, 9.52)
	Gas		9.52 × 2	9.52 × 2 *(9.52, 12.70)	9.52 × 2, 12.70 *(9.52 × 3)	9.52 × 2, 12.70 *(9.52 × 3)	9.52 × 2, 12.70 × 2 *(9.52 × 3, 12.70) *(9.52 × 2, 12.70, 15.88)
Max. Pipe Length	Total / Each	m	30 / 20	30 / 20	50 / 25	50 / 25	70 / 25
Max. Height Difference	Between Outdoor Unit and Each Indoor Units.	m	15	15	15	15	15
	Between Indoor Units.		10	10	10	10	10
Operation Range	Cooling	°CDB	10 to 46	10 to 46	-10 to 46	-10 to 46	0 to 46
	Heating		-15 to 24	-15 to 24	-15 to 24	-15 to 24	-10 to 24
Refrigerant	Type (Global Warming Potential)	R410A (2,088)		R410A (2,088)	R410A (2,088)	R410A (2,088)	R410A (2,088)
	Charge	kg(CO ₂ eq-1)	1.25 (2.6)	1.30 (2.7)	2.20 (4.6)	2.20 (4.6)	3.30 (6.9)

* Connect to connection valve by the adapter.

Dimensions

(Unit : mm)

2 Rooms:
 AOYG14LAC2/AOYG18LAC2

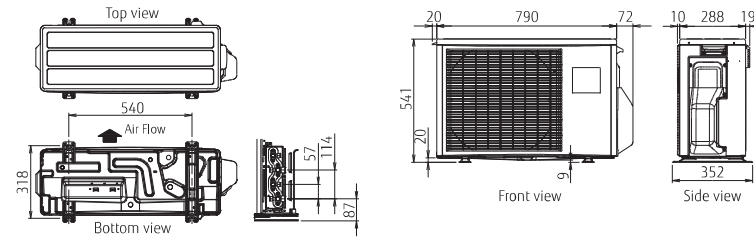

3 Rooms:
 AOYG18LAT3/AOYG24LAT3

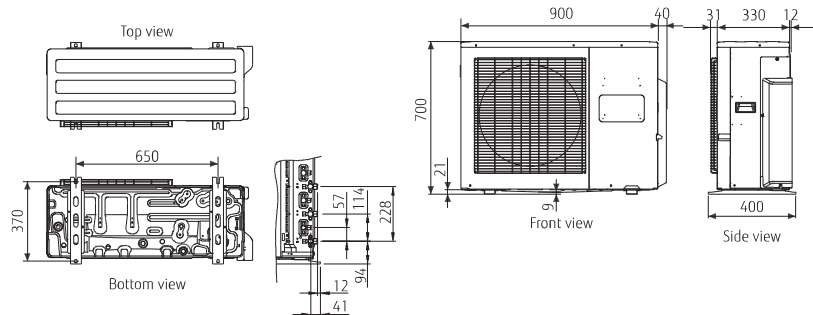

4 Rooms:
 AOYG30LAT4

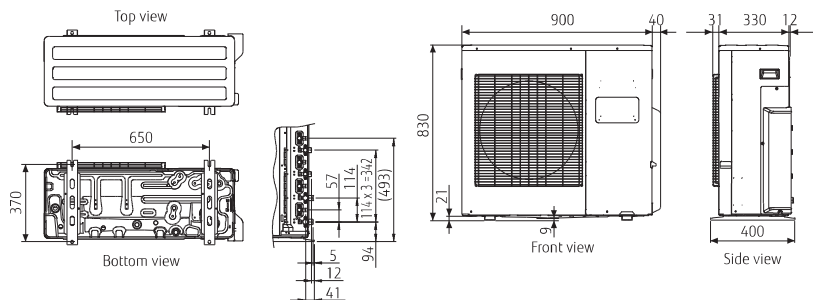

MULTI SPLIT

5 – 6 Rooms
Multi



Wide range of indoor units with various models

4 types / 16 models are lined up in the capacity range from 2.0 kW to 4.0 kW class. Wide range of requirements can be realized from in private homes, large shops and hotels.



Compact design

Multiple indoor units can be connected to 1 outdoor unit, and long piping connection is also possible. Compared with single type, the outdoor unit can be installed in various places to realize the space-saving installation.



Easy installation

All connected pipes and indoor units can be evacuated quickly via our centralized valve method. Requires evacuation only once



Central & Individual Control

- Batched control of up to 8 indoor units. The temperature, airflow volume, and remote control prohibition settings of all indoor units can be batched.
- Corresponds to 9 different languages (English, German, French, Spanish, Russian, Portuguese, Italian, Greek, and Turkish)
- Large backlight LED screen
- Large easy-to-see operation panel

Max. Controllable
1 multi system

Max. Controllable
8 indoor units



5 Rooms: AOYG36LBLA5
6 Rooms: AOYG45LBLA6



Specifications (5 Rooms, 6 Rooms)

Model No.			AOYG36LBLA5	AOYG45LBLA6
Power Source			Single-phase, ~230V, 50Hz	
Rated Capacity (min-max)	Cooling	kW	10.0 (3.5-12.5)	12.5 (3.5-14.0)
	Heating		12.0 (3.5-14.0)	13.5 (3.5-16.0)
EER	Cooling	W/W	4.10	3.50
	Heating		4.30	4.00
Sound Pressure Level (High)	Cooling	dB(A)	53	53
	Heating		55	55
Sound Power Level (High)	Cooling		67	67
	Heating		68	68
Airflow Rate	Cooling/Heating	m ³ /h	4,200/4,200	4,200/4,200
Net Dimensions H × W × D			998×970×370	998×970×370
Weight			94 (207)	94 (207)
Connection Pipe Diameter	Liquid	mm	6.35×5	6.35×6
	Gas		9.52 × 3, 12.70 × 2	9.52 × 4, 12.70 × 2
Max. Pipe Length		Total / Each	80 / 25	80 / 25
Max. Height Difference	Between Outdoor Unit and Each Indoor Units.	m	15	15
	Between Indoor Units.		10	10
Operation Range	Cooling	°CDB	-10 to 46	-10 to 46
	Heating		-15 to 24	-15 to 24
Refrigerant	Type (Global Warming Potential)		R410A (2,088)	R410A (2,088)
	Charge	kg(CO ₂ eq-T)	4.00 (8.4)	4.00 (8.4)

MULTI SPLIT

Dimensions

(Unit : mm)

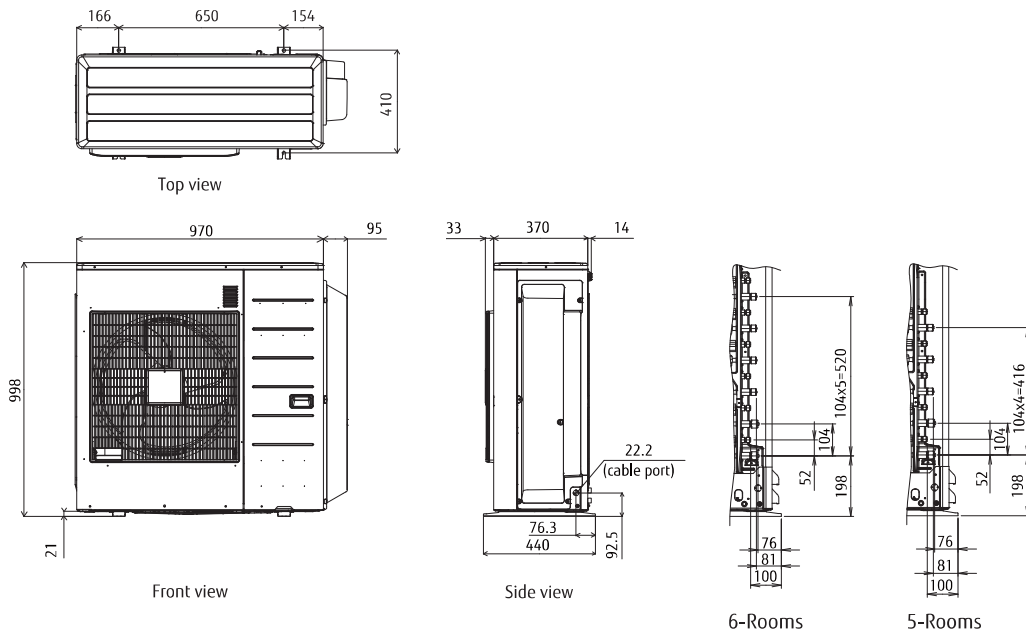

MULTI SPLIT



Compact outdoor unit

The compact design outdoor unit allows to be installed below a window and in a narrow space.



High seasonal efficiency

The actual performance is conducted under various outside temperatures depending on weather and seasons, furthermore, especially for multi system, not all the rooms are operated all the time. So over 90% of actual operation time, air conditioners are operated at partial capacity instead of rated capacity. Considering these, we focused on energy-saving performance which is based on actual use. Efficiency of part load performance was drastically improved by developing ALL DC and our own inverter system.

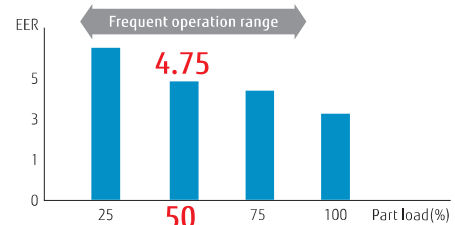

Innovated technology



High efficiency large fan:
High efficiency fan is mounted.



DC fan motor:
High performance and high efficiency has been realized by using a small DC fan motor.



Heat exchanger:
Reduced compact size and energy saving has been realized by utilizing high density piping design and 3-Row heat exchanger.



High efficiency DC twin rotary compressor:
A high performance, low noise, large capacity DC twin rotary compressor is used.

Quick comfort by optimized refrigerant control

Every room meets the set point most quickly and comfortably by optimized refrigerant control.

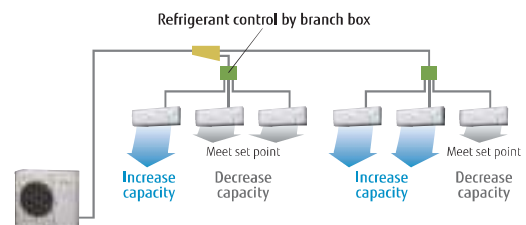

8 Rooms: AOYG45LBT8

Branch Box: UTP-PY03A / UTP-PY02A



Specifications (Outdoor unit/Branch box)

Outdoor Unit Model Name			AOYG45LBT8
Maximum Connectable Indoor Unit			8
Indoor Unit Connectable Capacity	Cooling	kW	11.0 - 17.5
Power source			Single-phase, ~230V, 50Hz
Rated Capacity	Cooling	kW	14.0
	Heating		16.0
Input Power	Cooling	kW	5.20
	Heating		5.07
Airflow rate	Cooling	m ³ /h	4,650
	Heating		4,800
Sound Pressure Level	Cooling	dB(A)	56
	Heating		58
Heat Exchanger Fin			Plate fin coil
Net Dimensions H × W × D		mm	914×970×370
Weight		kg(lbs)	98 (217)
Connection Pipe Diameter (Liquid / Gas)		mm	9.52/15.88
Max Pipe Length			115 (Total)
Max Height Difference (O.U ~ I.U)		m	30
Operating Range	Cooling	°CDB	-5 to 46
	Heating		-15 to 24
Refrigerant	Type (Global Warming Potential)		R410A (2,088)
	Charge	kg(CO2eq-T)	3.45 (7.2)

Branch Box Model Name			UTP-PY03A	UTP-PY02A
Connectable Indoor Unit			1 to 3 Units	1 to 2 Units
Power source			Single-phase, ~230V, 50Hz	Single-phase, ~230V, 50Hz
Available Voltage Range			198-264V	198-264V
Power Consumption		W	10	10
Running Current		A	0.05	0.05
Net Dimensions H × W × D		mm	195×433×370	195×433×370
Weight		kg(lbs)	9 (20)	9 (20)
Connection pipe diameter	Liquid	°CDB	Main: 9.52×1, Branch:6.35×3	Main: 9.52×1, Branch:6.35×2
	Gas		Main: 15.88×1, Branch:12.70×3	Main: 15.88×1, Branch:12.70×2
	Method		Flare	Flare

Note: Specifications are based on the following conditions.

- In case of connecting two indoor units(7 kW class).
- These are the measured values in the manufacturer's anechoic chamber.
- Cooling: Indoor temp. of 27°CDB/19°CWB, outdoor temp. of 35°CDB/24°CWB Heating: Indoor temp. of 20°CDB/15°CWB, outdoor temp. of 7°CDB/6°CWB
Pipe length: 5 m (Outdoor unit - Branch box), 3 m (Branch box - Indoor unit) Height difference : 0 m

Dimensions

(Unit : mm)

Outdoor Unit:
AOYG45LBT8

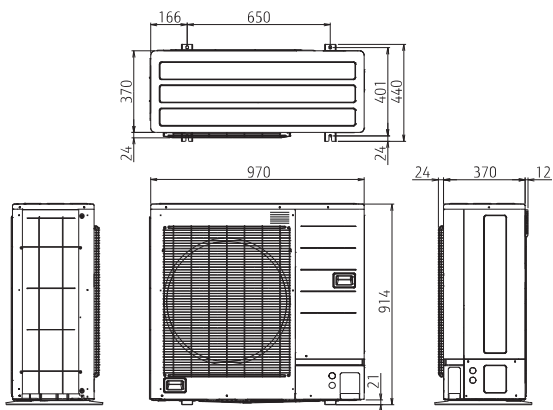

Branch Box :
UTP-PY03A (3 branches type)

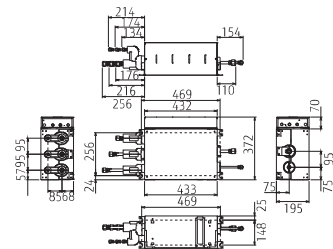

Branch Box :
UTP-PY02A (2 branches type)

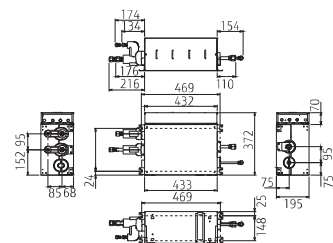

MULTI SPLIT

NEW

Simultaneous Multi Twin/Triple



Supports various installation scenes from office to commercial space, inside the same room and multi connection of up to 3 indoor units.

Selection of indoor units according to the room shape and heat load, like number of people and lighting conditions. Most comfortable air flow distribution can be realized.

Installation according to floor layout



Installation according to lighting conditions



Design flexibility

Slim & Compact design

This model is much more compact than a conventional outdoor unit. Significant reduced height of the product supports installations in narrow spaces.

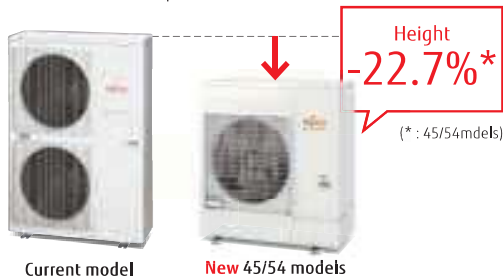

Flexible installation

Up to max. piping length of 50 m, max. height difference of 30 m can be supported. Multi type can be installed in large-size residence or buildings with multiple floors.

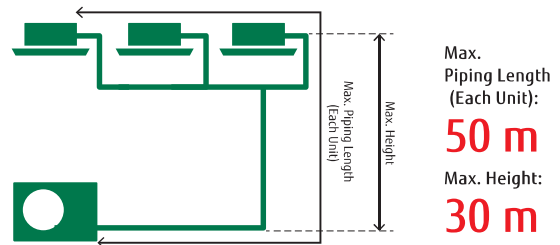

New Indoor unit lineup

3 types 6 models indoor units are provided, so you can select them depending on your room size and conditions.





Specifications (Indoor units/Outdoor units)

Indoor Units Model No.				Compact Cassette		
				AUXG18KVLA	AUXG22KVLA	AUXG24KVLA
Power Source				Single-phase, ~230V, 50Hz		
Airflow Rate	Cooling	H/M/L/Q	m ³ /h	680/580/490/410	830/740/600/450	930/830/600/450
	Heating	H/M/L/Q		800/680/580/450	860/760/700/530	930/850/700/530
Net Dimension H × W × D			mm	245x570x570	245x570x570	245x570x570
Weight			kg(lbs)	15 (33)	16 (35)	16 (35)
Cassette Grille				UTG-UFYF-W	UTG-UFYF-W	UTG-UFYF-W

Indoor Units Model No.				Duct		
				ARXG18KLLAP	ARXG22KMILA	ARXG24KMILA
Power Source				Single-phase, ~230V, 50Hz		
Airflow Rate	Cooling	H/M/L/Q	m ³ /h	940/880/820/750	1,100/910/750/580	1,100/910/750/580
	Heating	H/M/L/Q		940/880/820/750	1,100/910/750/580	1,100/910/750/580
Net Dimension H × W × D			mm	198x900x620	270x1,135x700	270x1,135x700
Weight			kg(lbs)	20 (44)	35 (77)	35 (77)

Outdoor Units Model No.			AOYG36KBTB	AOYG45KBTB	AOYG54KBTB
Capacity	Cooling	kW	9.5	12.1	13.4
	Heating		10.8	13.5	15.5
Power Source			Single-phase, ~230V, 50Hz		
Pdesign	Cooling	kW	-	-	-
	Heating (-10°C)		8.7	9.2	9.5
SEER	Cooling	W/W	6.10	-	-
SCOP	Heating		4.00	-	-
Annual Energy Consumption	Cooling	kWh/a	545	-	-
	Heating		3,043	-	-
Energy Efficiency Class	Cooling		A++	-	-
	Heating		A+	-	-
Sound Pressure Level (High)	Cooling	dB(A)	55	57	57
	Heating		55	57	59
Sound Power Level (High)	Cooling		70	71	73
	Heating		70	71	73
Airflow Rate	Cooling / Heating	m ³ /h	3,750/3,750	4,450/4,450	4,450/4,450
Net Dimension H × W × D			mm	788x940x320	998x940x320
Weight			kg(lbs)	52 (115)	67 (148)
Connection Pipe Diameter (Liquid / Gas)			mm	9.52/15.88	9.52/15.88
Max Pipe Length (Pre-Charge)			m	50 (30)	50 (30)
Height Difference			m	30	30
Operation Range	Cooling	°CDB	-15 to 46	-15 to 46	-15 to 46
	Heating		-15 to 24	-15 to 24	-15 to 24
Refrigerant	Type (Global Warming Potential)	R32 (675)			
	Charge	kg(CO2eq-1)	1.90(1.283)	2.70(1.823)	2.70(1.823)
Separation tube			UTP-SX236A (Twin)	UTP-SX236A (Twin)	UTP-SX236A (Twin) UTP-SX354A (Triple)

- Different type and capacity indoor units cannot be connected.
- The above table is the value for connecting with cassette type.

Dimensions

(Unit : mm)

AOYG36KBTB

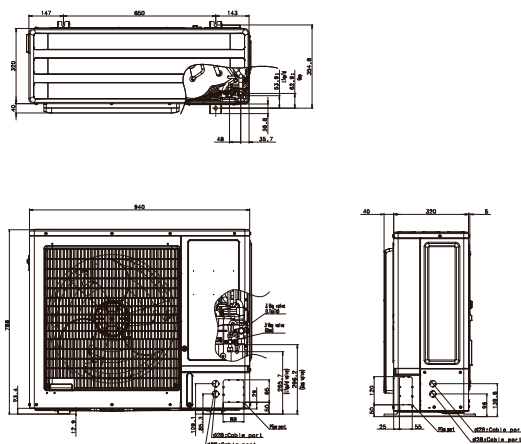

AOYG45KBTB / AOYG54KBTB

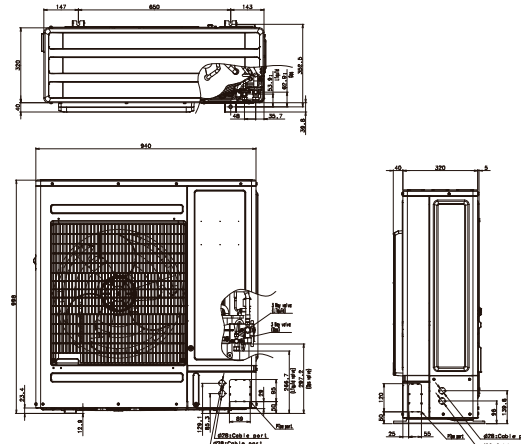

MULTI SPLIT



Supports various installation scenes from office to commercial space, inside the same room and multi connection of up to 3 indoor units.

Selection of indoor units according to the room shape and heat load, like number of people and lighting conditions. Most comfortable air flow distribution can be realized.

Installation according to floor layout



Installation according to lighting conditions



Installation according to layout and lighting conditions

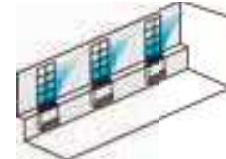

Simultaneous control

Max 16 indoor units are simultaneously controlled with a wired remote controller.

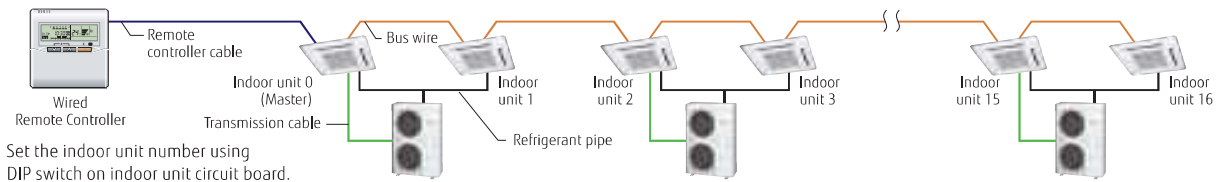

Indoor unit lineup

4 types 9 models indoor units are provided, so you can select them depending on your room size and conditions.



Compact Cassette



Slim Duct



Duct



Floor/Ceiling Universal

**Model : AOYG36LBTB / AOYG45LBTB / AOYG54LBTB
AOYG36LATT [3phase] / AOYG45LATT [3phase] / AOYG54LATT [3phase]**



Specifications (Indoor units/Outdoor units)

Indoor Units Model No.				Compact Cassette		
				AUYG18LVLB	AUYG22LVLA	AUYG24LVLA
Power Source				Single-phase, ~230V, 50Hz		
Airflow Rate	Cooling	H/M/L/Q	m ³ /h	750/610/520/410	930/830/600/450	930/830/600/450
	Heating	H/M/L/Q		800/710/600/450	930/860/700/530	930/830/600/450
Net Dimension H × W × D				mm		
				245×570×570		
Weight				kg(lbs)		
				15 (33)		
Cassette Grille				UTG-UFYD-W		

Indoor Units Model No.				Duct			Floor/Ceiling Universal		
				ARYG18LLTB	ARYG22LMLA	ARYG24LMLA	ABYG18LVTB	ABYG22LVTA	ABYG24LVTA
Power Source				Single-phase, ~230V, 50Hz			Single-phase, ~230V, 50Hz		
Airflow Rate	Cooling	H/M/L/Q	m ³ /h	940/880/820/750	1,100/910/750/580	780/700/560/500	980/820/680/540		
	Heating	H/M/L/Q		940/880/820/750	1,100/910/750/580	780/700/560/500	980/820/680/540		
Net Dimension H × W × D				mm			199 × 900 × 620		
Weight				kg(lbs)			27 (60)		

Outdoor Units Model No.			AOYG36LBTB	AOYG45LBTB	AOYG54LBTB	AOYG36LATT	AOYG45LATT	AOYG54LATT
Capacity	Cooling	kW	10.0	12.1	13.3	10.0	12.5	14.0
	Heating		11.2	14.0	15.0	11.2	14.0	16.0
Power Source			Single-phase, ~230V, 50Hz			3-phase, ~400V, 50Hz		
Pdesign	Cooling	kW	10.0	-	-	10.0	-	-
	Heating (-10°C)		10.0	-	-	10.0	-	-
SEER	Cooling	W/W	5.56	-	-	6.00	-	-
SCOP	Heating		3.90	-	-	4.00	-	-
Annual Energy Consumption	Cooling	kWh/a	629	-	-	583	-	-
	Heating		3,588	-	-	3,499	-	-
Energy Efficiency Class	Cooling		A	-	-	A+	-	-
	Heating		A	-	-	A+	-	-
Sound Pressure Level (High)	Cooling	dB(A)	52	54	55	51	54	55
Sound Power Level (High)	Heating		69	70	72	69	69	71
Airflow Rate	Cooling / Heating	m ³ /h	6,200/6,200	6,750/6,200	6,850/6,750	6,200/6,200	6,750/6,200	6,900/6,900
Net Dimension H × W × D			mm			1,290×900×330		
Weight			kg(lbs)			93(205)		
Connection Pipe Diameter (Liquid / Gas)			mm			9.52/15.88		
Max Pipe Length (Pre-Charge)			m			75(30)		
Height Difference			m			30		
Operation Range	Cooling	°CDB	-15 to 46	-15 to 46	-15 to 46	-15 to 46	-15 to 46	-15 to 46
	Heating		-15 to 24	-15 to 24	-15 to 24	-15 to 24	-15 to 24	-15 to 24
Refrigerant	Type (Global Warming Potential)		R410A (2,088)	R410A (2,088)	R410A (2,088)	R410A (2,088)	R410A (2,088)	R410A (2,088)
	Charge	kg(CO2eq-T)	3.45 (7.2)	3.45 (7.2)	3.45 (7.2)	3.45 (7.2)	3.45 (7.2)	3.45 (7.2)
Separation tube			UTP-SX236A(Twin) UTP-SX254A(Twin) UTP-SX354A(Triple)			UTP-SX236A (Twin) UTP-SX254A (Twin) UTP-SX354A (Triple)		

*Different type and capacity indoor units cannot be connected.
*The above table is the value for connecting with cassette type.

Dimensions

(Unit : mm)

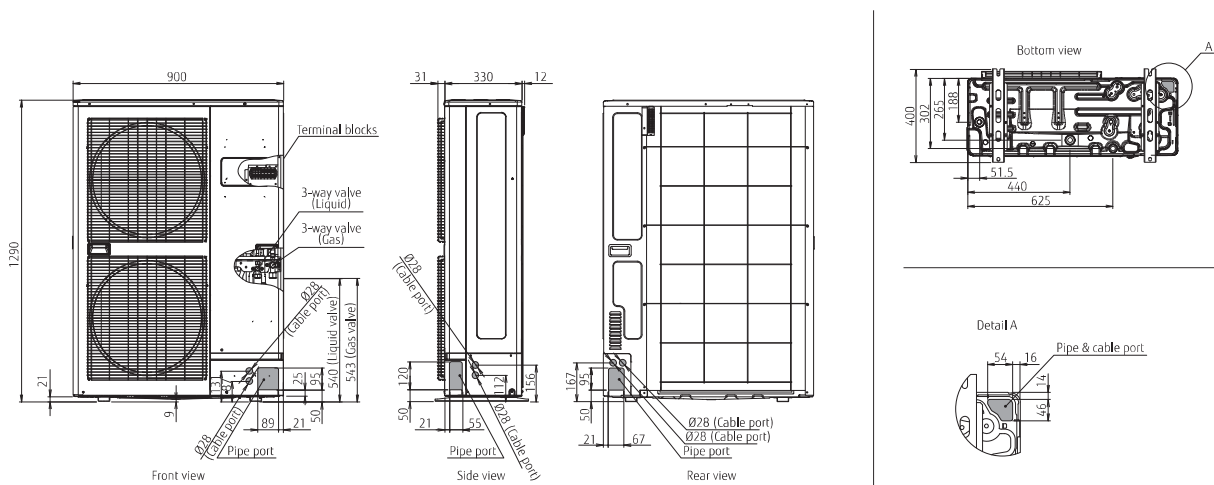

MULTI SPLIT

MULTI SPLIT

Simultaneous Multi Twin/Triple/Double Twin



Support various applications from open plan offices to retail stores, with up to 4 indoor units.

Selection of indoor units according to the room shape and heat load, like number of people and lighting conditions. Most comfortable air flow distribution can be realized.

Installation according to floor layout

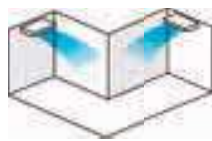

Installation according to lighting conditions



Installation according to layout and lighting conditions



Installation according to large space



Simultaneous control

Max 16 indoor units are simultaneously controlled with a wired remote controller.

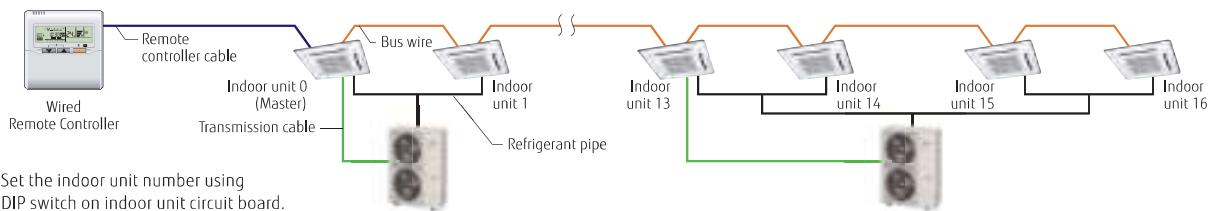

Set the indoor unit number using DIP switch on indoor unit circuit board.

*When using a wireless remote controller, the following functions cannot be used: Timer operation, Sleep Timer operation, 10°C Heat operation

Indoor unit lineup

6 types 18 models indoor units are provided, so you can select them depending on your room size and conditions.



Compact Cassette



Cassette



Slim Duct



Duct



Floor/Ceiling Universal



Ceiling

Model: AOYG72LRLA [3phase] / AOYG90LRLA [3phase]



Specifications (Indoor units/Outdoor units)

Indoor Units Model No.				Compact Cassette, Cassette					
				AUYG18LVLB	AUYG22LVLA	AUYG24LVLA	AUYG30LRLE	AUYG36LRLE	AUYG45LRLA
Power Source				Single-phase, ~230V, 50Hz					
Airflow Rate	Cooling	H/M/L/Q	m ³ /h	750/610/520/410	930/830/600/450	930/830/600/450	1,600/1,400/1,270/1,150	1,800/1,400/1,270/1,150	1,900/1,640/1,460/1,250
	Heating	H/M/L/Q		800/710/600/450	930/860/700/530	930/830/600/450	1,800/1,400/1,270/1,150	1,800/1,400/1,270/1,150	1,900/1,640/1,460/1,250
Net Dimension H × W × D			mm	245×570×570	245×570×570	245×570×570	288 × 840 × 840	288 × 840 × 840	288 × 840 × 840
Weight			kg(lbs)	15 (33)	16 (35)	16 (35)	26 (57)	26 (57)	26 (57)
Cassette Grille				UTG-UFYD-W			UTG-UGYA-W		

Indoor Units Model No.				Duct					
				ARYG18LLTB	ARYG22LMLA	ARYG24LMLA	ARYG30LMLE	ARYG36LMLE	ARYG45LMLA
Power Source				Single-phase, ~230V, 50Hz					
Airflow Rate	Cooling	H/M/L/Q	m ³ /h	940/880/820/750	1,100/910/750/580	1,100/910/750/580	1,900/1,620/1,270/980	1,900/1,620/1,270/980	2,100/1,750/1,350/1,070
	Heating	H/M/L/Q		940/880/820/750	1,100/910/750/580	1,100/910/750/580	2,100/1,620/1,270/980	2,100/1,620/1,270/980	2,100/1,750/1,350/1,070
Net Dimension H × W × D			mm	198 × 900 × 620	270 × 1135 × 700	270 × 1135 × 700	270 × 1135 × 700	270 × 1135 × 700	270 × 1135 × 700
Weight			kg(lbs)	23 (51)	38 (84)	38 (84)	40 (88)	40 (88)	40 (88)

Indoor Units Model No.				Floor/Ceiling, Ceiling					
				ABYG18LVTB	ABYG22LVTA	ABYG24LVTA	ABYG30LRTE	ABYG36LRTE	ABYG45LRTE
Power Source				Single-phase, ~230V, 50Hz					
Airflow Rate	Cooling	H/M/L/Q	m ³ /h	780/700/560/500	980/820/680/540	980/820/680/540	1,660/1,500/1,200/1,000	1,900/1,500/1,200/1,000	2,100/1,700/1,400/1,100
	Heating	H/M/L/Q		780/700/560/500	980/820/680/540	980/820/680/540	1,660/1,500/1,200/1,000	1,900/1,500/1,200/1,000	2,100/1,700/1,400/1,100
Net Dimension H × W × D			mm	199 × 990 × 655	199 × 990 × 655	199 × 990 × 655	240 × 1660 × 700	240 × 1660 × 700	240 × 1660 × 700
Weight			kg(lbs)	27 (60)	27 (60)	27 (60)	46 (101)	46 (101)	46 (101)

Outdoor Units Model No.			AOYG72LRLA		AOYG90LRLA	
Capacity	Cooling	kW	19.0		22.0	
	Heating		22.4		27.0	
Power Source			3-phase, ~400V, 50Hz			
Sound Pressure Level (High)	Cooling	dB(A)	55		55	
Airflow Rate	Cooling / Heating		8,400/8,400		8,400/9,000	
Net Dimension H × W × D			mm		1,428×1,080×480	
Weight			kg(lbs)		172 (378)	
Connection Pipe Diameter (Liquid / Gas)			mm		12.7/25.4	
Max Pipe Length (Pre-Charge)			m		100 (30)	
Height Difference			m		30	
Operation Range	Cooling	°CDB	-15 to 46		-15 to 46	
	Heating		-20 to 24		-20 to 24	
Refrigerant	Type (Global Warming Potential)		R410A (2,088)		R410A (2,088)	
	Charge	kg(CO2eq-T)	5.6 (11.7)		7.1 (14.8)	

- Different type and capacity indoor units cannot be connected.
- The above table is the value for connecting with cassette type.

*: That specification is not fixed yet.

Dimensions

(Unit : mm)

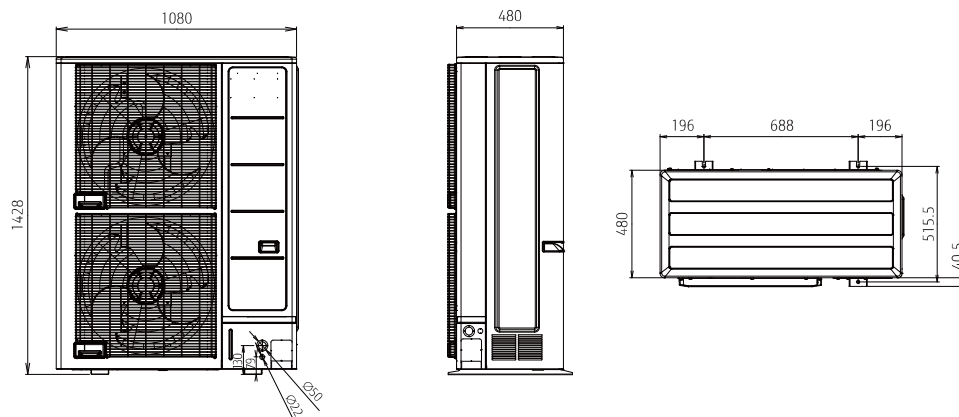

MULTI SPLIT

New 2 Rooms Multi Indoor Units Specifications



Wall mounted



Model No.	Indoor unit			ASYG07KGTB	ASYG09KGTB	ASYG12KGTB	ASYG14KGTB
kW Class	kW			2.0	2.5	3.5	4.0
Power Source	Single-phase, ~230V, 50Hz						
Sound Pressure Level	Cooling	H/M/L/Q	dB(A)	38/33/29/21	40/34/29/21	40/35/30/21	43/36/30/21
	Heating			41/35/31/22	42/36/31/22	42/38/33/22	44/39/33/24
Sound Power Level	Cooling	H	dB(A)	54	55	55	57
	Heating			56	57	58	59
Airflow Rate	Cooling	H/M/L/Q	m ³ /h	650/540/430/270	700/560/430/270	700/560/430/250	770/600/450/280
	Heating			720/580/460/330	750/610/470/330	770/640/520/330	800/660/520/340
Net Dimensions				mm	270x834x215	270x834x215	270x834x215
Weight				kg(lbs)	10 (22)	10 (22)	10 (22)
Connection Pipe Diameter	Liquid/Gas			mm	6.35/9.52	6.35/9.52	6.35/9.52

Wall mounted



Model No.	Indoor unit			ASYG07KMTB	ASYG09KMTB	ASYG12KMTB	ASYG14KMTB
kW Class	kW			2.0	2.5	3.5	4.0
Power Source	Single-phase, ~230V, 50Hz						
Sound Pressure Level	Cooling	H/M/L/Q	dB(A)	38/33/29/21	40/34/29/21	40/35/30/21	43/36/30/21
	Heating			41/35/31/22	42/36/31/22	42/38/33/22	44/39/33/24
Sound Power Level	Cooling	H	dB(A)	54	55	55	57
	Heating			56	57	58	59
Airflow Rate	Cooling	H/M/L/Q	m ³ /h	650/540/430/270	700/560/430/270	700/560/430/270	770/600/450/280
	Heating			720/580/460/330	750/610/470/330	770/640/520/330	800/660/520/340
Net Dimensions				mm	270x834x222	270x834x222	270x834x222
Weight				kg(lbs)	10 (22)	10 (22)	10 (22)
Connection Pipe Diameter	Liquid/Gas			mm	6.35/9.52	6.35/9.52	6.35/9.52



Compact cassette Grid type



Model No.	Indoor unit			AUXG07KVLA	AUXG09KVLA	AUXG12KVLA	AUXG14KVLA
kW Class	kW			2.0	2.5	3.5	4.0
Power Source	Single-phase, ~230V, 50Hz						
Sound Pressure Level	Cooling	H/M/L/Q	dB(A)	33/31/29/27	33/31/29/27	37/34/31/28	38/35/32/29
	Heating			34/32/29/27	34/32/29/27	37/34/31/29	43/38/34/30
Sound Power Level	Cooling	H	dB(A)	46	46	49	50
	Heating			47	47	49	55
Airflow Rate	Cooling	H/M/L/Q	m ³ /h	540/490/440/390	540/490/440/390	610/530/470/410	680/580/490/410
	Heating			540/490/440/390	540/490/440/390	610/530/470/410	790/680/580/450
Net Dimensions	mm			245x570x570	245x570x570	245x570x570	245x570x570
Weight	kg(lbs)			15 (33)	15 (33)	15 (33)	15 (33)
Panel				UTG-UFYF-W	UTG-UFYF-W	UTG-UFYF-W	UTG-UFYF-W
Connection Pipe Diameter	Liquid/Gas	mm		6.35/9.52	6.35/9.52	6.35/9.52	6.35/9.52

Mini duct



Model No.	Indoor unit			ARXG07KSLAP	ARXG09KSLAP	ARXG12KSLAP	ARXG14KSLAP
kW Class	kW			2.0	2.5	3.5	4.0
Power Source	Single-phase, ~230V, 50Hz						
Sound Pressure Level	Cooling	H/M/L/Q	dB(A)	29/26/24/23	29/26/24/23	31/27/25/23	35/30/27/23
	Heating			29/26/24/23	29/26/24/23	31/27/25/23	35/30/27/23
Sound Power Level	Cooling	H	dB(A)	52	54	55	60
	Heating			53	56	57	62
Airflow Rate	Cooling	H/M/L/Q	m ³ /h	550/440/390/360	600/450/400/360	650/490/430/360	800/640/530/360
	Heating			550/440/390/360	600/450/400/360	650/490/430/360	800/640/530/360
Net Dimensions	mm			198x700x450	198x700x450	198x700x450	198x700x450
Weight	kg(lbs)			15.5 (34)	15.5 (34)	15.5 (34)	15.5 (34)
Connection Pipe Diameter	Liquid/Gas	mm		6.35/9.52	6.35/9.52	6.35/9.52	6.35/9.52
External static pressure	Pa			0 to 30	0 to 30	0 to 30	0 to 50
Drain pump	Standard						

Slim duct



Model No.	Indoor unit			ARXG07KLLAP	ARXG09KLLAP	ARXG12KLLAP	ARXG14KLLAP
kW Class	kW			2.0	2.5	3.5	4.0
Power Source	Single-phase, ~230V, 50Hz						
Sound Pressure Level	Cooling	H/M/L/Q	dB(A)	28/26/25/24	28/27/26/25	29/28/27/26	32/30/28/26
	Heating			28/26/25/24	28/26/25/24	29/28/27/26	32/30/28/25
Sound Power Level	Cooling	H	dB(A)	57	57	58	60
	Heating			57	57	58	60
Airflow Rate	Cooling	H/M/L/Q	m ³ /h	550/490/470/440	600/550/500/450	650/600/550/480	800/700/600/480
	Heating			550/490/470/440	600/550/500/450	650/600/550/480	800/700/600/480
Net Dimensions	mm			198x700x620	198x700x620	198x700x620	198x700x620
Weight	kg(lbs)			16 (35)	17 (37)	17 (37)	17 (37)
Connection Pipe Diameter	Liquid/Gas	mm		6.35/9.52	6.35/9.52	6.35/9.52	6.35/9.52
External static pressure	Pa			0 to 90	0 to 90	0 to 90	0 to 90
Drain pump	Standard						

MULTI SPLIT

2 - 8 Rooms Multi Indoor Units Specifications

Compact wall mounted



Model No.	Indoor unit			ASYG07LUCA	ASYG09LUCA	ASYG12LUCA	ASYG14LUCA
kW Class	kW			2.0	2.5	3.5	4.0
Power Source	Single-phase, ~230V, 50Hz						
Sound Pressure Level	Cooling	H/M/L/Q	dB(A)	35/30/28/21	36/32/28/21	37/34/31/21	41/36/33/25
	Heating			35/30/28/21	36/32/28/21	37/34/31/21	41/36/34/27
Sound Power Level	Cooling	H	dB(A)	53	54	55	59
	Heating			53	54	55	59
Airflow Rate	Cooling	H/M/L/Q	m³/h	570/520/470/330	600/550/470/330	660/600/530/330	710/640/570/390
	Heating			570/520/470/330	600/550/470/330	660/600/530/330	710/640/590/430
Net Dimensions				282×870×185	282×870×185	282×870×185	282×870×185
Weight	kg(lbs)			9.5 (21)	9.5 (21)	9.5 (21)	9.5 (21)
Connection Pipe Diameter	Liquid/Gas	mm		6.35/9.52	6.35/9.52	6.35/9.52	6.35/12.70

Wall mounted



Model No.	Indoor unit			ASYG18LFCA	ASYG24LFCC
kW Class	kW			5.0	7.0
Power Source	Single-phase, ~230V, 50Hz				
Sound Pressure Level	Cooling	H/M/L/Q	dB(A)	43/37/33/26	49/42/37/33
	Heating			42/37/33/25	48/42/37/33
Sound Power Level	Cooling	H	dB(A)	58	64
	Heating			58	64
Airflow Rate	Cooling	H/M/L/Q	m³/h	900/740/620/550	1,120/900/740/620
	Heating			900/740/620/550	1,100/900/740/620
Net Dimensions	mm			320×998×238	320×998×238
Weight	kg(lbs)			14 (30.8)	14 (30.8)
Connection Pipe Diameter	Liquid/Gas	mm		6.35/12.70	6.35/15.88

Compact wall mounted



Model No.	Indoor unit			ASYG07LMCE	ASYG09LMCE	ASYG12LMCE	ASYG14LMCE
kW Class	kW			2.0	2.5	3.5	4.0
Power Source	Single-phase, ~230V, 50Hz						
Sound Pressure Level	Cooling	H/M/L/Q	dB(A)	36/32/29/21	37/33/29/21	40/36/30/21	42/38/33/25
	Heating			36/32/29/22	37/33/29/22	40/36/31/22	42/38/35/27
Sound Power Level	Cooling	H	dB(A)	51	52	54	56
	Heating			51	52	55	57
Airflow Rate	Cooling	H/M/L/Q	m³/h	560/500/430/310	600/520/430/310	660/560/450/310	730/600/530/360
	Heating			560/500/430/330	600/520/430/330	660/560/470/330	730/615/560/375
Net Dimensions	mm			270×870×204	270×870×204	270×870×204	270×870×204
Weight	kg(lbs)			8.5 (18.7)	8.5 (18.7)	8.5 (18.7)	8.5 (18.7)
Connection Pipe Diameter	Liquid/Gas	mm		6.35/9.52	6.35/9.52	6.35/9.52	6.35/12.70

Floor



Model No.	Indoor unit			AGYG09LVCA	AGYG12LVCA	AGYG14LVCA
kW Class	kW			2.5	3.5	4.0
Power Source	Single-phase, ~230V, 50Hz					
Sound Pressure Level	Cooling	H/M/L/Q	dB(A)	39/34/28/22	42/36/30/22	44/38/31/22
	Heating			39/35/30/22	42/38/32/22	44/39/33/22
Sound Power Level	Cooling	H	dB(A)	52	55	56
	Heating			52	55	56
Airflow Rate	Cooling	H/M/L/Q	m³/h	530/440/360/270	600/490/380/270	650/520/400/270
	Heating			530/460/380/270	600/510/410/270	650/540/430/270
Net Dimensions	mm			600×740×200	600×740×200	600×740×200
Weight	kg(lbs)			14 (30.7)	14 (30.7)	14 (30.7)
Connection Pipe Diameter	Liquid/Gas	mm		6.35/9.52	6.35/9.52	6.35/12.70

Floor ceiling



Model No.		Indoor unit		ABYG14LVTA		ABYG18LVTB	
kW Class		kW		4.0		5.0	
Power Source		Single-phase, ~230V, 50Hz					
Sound Pressure Level	Cooling	H/M/L/Q	dB(A)	36/34/33/29 (Under ceiling) 39/37/36/32 (Floor console)		41/38/34/32 (Under ceiling) 44/41/37/35 (Floor console)	
	Heating			36/34/33/29 (Under ceiling) 39/37/36/32 (Floor console)		41/38/34/32 (Under ceiling) 44/41/37/35 (Floor console)	
Sound Power Level	Cooling	H	dB(A)	51		55	
	Heating			51		55	
Airflow Rate	Cooling	H/M/L/Q	m³/h	640/590/540/480		780/700/560/500	
	Heating			640/590/540/480		780/700/560/500	
Net Dimensions		mm		199×990×655		199×990×655	
Weight		kg(lbs)		27 (60)		27 (60)	
Connection Pipe Diameter		Liquid/Gas		6.35/12.70		6.35/12.70	

Compact cassette



Model No.		Indoor unit		AUYG07LVLA	AUYG09LVLA	AUYG12LVLB	AUYG14LVLB	AUYG18LVLB	
kW Class		kW		2.0	2.5	3.5	4.0	5.0	
Power Source		Single-phase, ~230V, 50Hz							
Sound Pressure Level	Cooling	H/M/L/Q	dB(A)	33/31/29/27	33/31/29/27	37/33/31/28	40/35/32/29	42/37/33/29	
	Heating			34/32/29/27	34/32/29/27	37/33/31/28	40/37/34/29	44/40/37/30	
Sound Power Level	Cooling	H	dB(A)	46	46	49	52	54	
	Heating			47	47	49	52	56	
Airflow Rate	Cooling	H/M/L/Q	m³/h	540/490/440/390	540/490/440/390	610/530/470/410	680/580/490/410	750/610/520/410	
	Heating			540/490/440/390	540/490/440/390	610/530/470/410	700/620/550/430	800/710/600/450	
Net Dimensions		mm		245×570×570		245×570×570		245×570×570	
Weight		kg(lbs)		15 (33.1)		15 (33.1)		15 (33.1)	
Panel		UTG-UFYD-W							
Connection Pipe Diameter		Liquid/Gas		6.35/9.52		6.35/9.52		6.35/12.70	

Mini duct



Model No.		Indoor unit		ARYG07LSLAP	ARYG09LSLAP	ARYG12LSLAP	ARYG14LSLAP	ARYG18LSLAP	
kW Class		kW		2.0	2.5	3.5	4.0	5.0	
Power Source		Single-phase, ~230V, 50Hz							
Sound Pressure Level	Cooling	H/M/L/Q	dB(A)	29/26/24/23	29/26/24/23	31/27/25/23	35/30/27/23	33/29/26/23	
	Heating			29/26/24/23	29/26/24/23	31/27/25/23	35/30/27/23	33/29/26/23	
Sound Power Level	Cooling	H	dB(A)	52	54	55	60	58	
	Heating			53	56	57	62	59	
Airflow Rate	Cooling	H/M/L/Q	m³/h	550/440/390/360	600/450/400/360	650/490/430/360	800/640/530/360	940/750/540/480	
	Heating			550/440/390/360	600/450/400/360	650/490/430/360	800/640/530/360	940/750/540/480	
Net Dimensions		mm		198×700×450		198×700×450		198×900×450	
Weight		kg(lbs)		15.5 (34.1)				18.5 (40.7)	
Connection Pipe Diameter		Liquid/Gas		6.35/9.52			6.35/12.70		
External static pressure		Pa		0 to 30			0 to 50		
Drain pump		Standard							

Slim duct



Model No.		Indoor unit		ARYG07LLTA	ARYG09LLTA	ARYG12LLTB	ARYG14LLTB	ARYG18LLTB	
kW Class		kW		2.0	2.5	3.5	4.0	5.0	
Power Source		Single-phase, ~230V, 50Hz							
Sound Pressure Level	Cooling	H/M/L/Q	dB(A)	28/26/25/24	28/27/26/25	29/28/27/26	32/30/28/26	32/31/30/29	
	Heating			28/26/25/24	28/26/25/24	29/28/27/24	33/30/28/25	33/32/31/29	
Sound Power Level	Cooling	H	dB(A)	57	57	58	60	58	
	Heating			57	57	58	61	59	
Airflow Rate	Cooling	H/M/L/Q	m³/h	550/490/470/440	600/550/500/450	650/600/550/480	800/700/600/480	940/880/820/750	
	Heating			550/490/470/440	600/550/500/450	650/600/550/480	800/700/600/480	940/880/820/750	
Net Dimensions		mm		198×700×620		198×700×620		198×900×620	
Weight		kg(lbs)		17 (37.5)		19 (41.8)		23 (50.6)	
Connection Pipe Diameter		Liquid/Gas		6.35/9.52		6.35/9.52		6.35/12.70	
External static pressure		Pa		0 to 90					
Drain pump		Standard							

2 Rooms Multi Combination Table–Cooling/Heating



2 Rooms Multi cooling

AOYG14KBTA2	Combination of Indoor Unit		COOLING OPERATION							
			Cooling Capacity			Input Power (min-max)	EER	Seasonal Data		
			Room 1 kW	Room 2 kW	Total Capacity (min-max) kW			Pdesign kW	SEER	Energy efficiency class
2 Room	7	7	2.00	2.00	4.00(1.4-4.6)	0.97(0.25 - 1.20)	4.12	4.0	8.7	A+++
	7	9	1.75	2.25	4.00(1.4-4.6)	0.97(0.25 - 1.20)	4.12	4.0	8.7	A+++
	7	12	1.47	2.53	4.00(1.4-4.6)	0.97(0.25 - 1.20)	4.12	4.0	8.7	A+++
	9	9	2.00	2.00	4.00(1.4-4.6)	0.97(0.25 - 1.20)	4.12	4.0	8.7	A+++
	9	12	1.71	2.29	4.00(1.4-4.6)	0.97(0.25 - 1.20)	4.12	4.0	8.7	A+++

Note: •7:7000Btu/h / 9:9000Btu/h / 12:12000Btu/h models
 •The above is the value for connecting with Wall Mounted [KG] type.
 •2 or more indoor units should be connected.
 •Cooling capacity is based on 27°CDB/19°CWB (indoor temperature), 35°CDB (outdoor temperature).
 •Pipe Length: 5 m, Height difference: 0 m (Outdoor unit to Indoor unit)
 •The Total ability of connected indoor unit is up to 21000Btu from 14000Btu.

AOYG18KBTA2	Combination of Indoor Unit		COOLING OPERATION							
			Cooling Capacity			Input Power (min-max)	EER	Seasonal Data		
			Room 1 kW	Room 2 kW	Total Capacity (min-max) kW			Pdesign kW	SEER	Energy efficiency class
2 Room	7	7	2.00	2.00	4.00(1.7-5.0)	0.92(0.25 - 1.23)	4.35	4.0	8.8	A+++
	7	9	2.00	2.50	4.50(1.7-5.7)	1.07(0.25 - 1.45)	4.22	4.5	8.7	A+++
	7	12	1.84	3.16	5.00(1.7-5.8)	1.24(0.25 - 1.55)	4.03	5.0	8.6	A+++
	7	14	1.67	3.33	5.00(1.7-5.8)	1.24(0.25 - 1.55)	4.03	5.0	8.6	A+++
	9	9	2.50	2.50	5.00(1.7-5.8)	1.24(0.25 - 1.55)	4.03	5.0	8.6	A+++
	9	12	2.14	2.86	5.00(1.7-5.8)	1.24(0.25 - 1.55)	4.03	5.0	8.6	A+++
	9	14	1.96	3.04	5.00(1.7-5.8)	1.24(0.25 - 1.55)	4.03	5.0	8.6	A+++
	12	12	2.50	2.50	5.00(1.7-5.8)	1.24(0.25 - 1.55)	4.03	5.0	8.6	A+++
	12	14	2.31	2.69	5.00(1.7-5.8)	1.24(0.25 - 1.55)	4.03	5.0	8.6	A+++

Note: •7:7000Btu/h / 9:9000Btu/h / 12:12000Btu/h / 14:14000Btu/h models
 •The above is the value for connecting with Wall Mounted [KG] type.
 •2 or more indoor units should be connected.
 •Cooling capacity is based on 27°CDB/19°CWB (indoor temperature), 35°CDB (outdoor temperature).
 •Pipe Length: 5 m, Height difference: 0 m (Outdoor unit to Indoor unit)
 •The Total ability of connected indoor unit is up to 26000Btu from 14000Btu.

2 Rooms Multi heating

AOYG14KBTA2	Combination of Indoor Unit		HEATING OPERATION							
			Heating Capacity			Input Power (min-max)	COP	Seasonal Data		
			Room 1 kW	Room 2 kW	Total Capacity (min-max) kW			Pdesign kW	SCOP	Energy efficiency class
2 Room	7	7	2.20	2.20	4.40(1.1-5.5)	0.95(0.25 - 1.65)	4.63	3.5	4.7	A++
	7	9	1.92	2.48	4.40(1.1-5.5)	0.95(0.25 - 1.65)	4.63	3.5	4.7	A++
	7	12	1.62	2.78	4.40(1.1-5.5)	0.95(0.25 - 1.65)	4.63	3.5	4.7	A++
	9	9	2.20	2.20	4.40(1.1-5.5)	0.95(0.25 - 1.65)	4.63	3.5	4.7	A++
	9	12	1.89	2.51	4.40(1.1-5.5)	0.95(0.25 - 1.65)	4.63	3.5	4.7	A++

Note: •7:7000Btu/h / 9:9000Btu/h / 12:12000Btu/h models
 •The above is the value for connecting with Wall Mounted [KG] type.
 •2 or more indoor units should be connected.
 •Heating capacity is based on 20°CDB (indoor temperature), 7°CDB/6°CWB (outdoor temperature).
 •Pipe Length: 5 m, Height difference: 0 m (Outdoor unit to Indoor unit)
 •The Total ability of connected indoor unit is up to 21000Btu from 14000Btu.

AOYG18KBTA2	Combination of Indoor Unit		HEATING OPERATION							
			Heating Capacity			Input Power (min-max)	COP	Seasonal Data		
			Room 1 kW	Room 2 kW	Total Capacity (min-max) kW			Pdesign kW	SCOP	Energy efficiency class
2 Room	7	7	2.40	2.40	4.80(1.7-5.6)	0.99(0.25 - 1.35)	4.85	3.8	4.7	A++
	7	9	2.40	3.00	5.40(1.7-6.4)	1.15(0.25 - 1.60)	4.70	4.0	4.7	A++
	7	12	2.06	3.54	5.60(1.7-7.0)	1.22(0.25 - 1.80)	4.59	4.2	4.7	A++
	7	14	1.87	3.73	5.60(1.7-7.0)	1.22(0.25 - 1.80)	4.59	4.2	4.7	A++
	9	9	2.80	2.80	5.60(1.7-7.0)	1.22(0.25 - 1.80)	4.59	4.2	4.7	A++
	9	12	2.40	3.20	5.60(1.7-7.0)	1.22(0.25 - 1.80)	4.59	4.2	4.7	A++
	9	14	2.19	3.41	5.60(1.7-7.0)	1.22(0.25 - 1.80)	4.59	4.2	4.7	A++
	12	12	2.80	2.80	5.60(1.7-7.0)	1.22(0.25 - 1.80)	4.59	4.2	4.7	A++
	12	14	2.58	3.02	5.60(1.7-7.0)	1.22(0.25 - 1.80)	4.59	4.2	4.7	A++

Note: •7:7000Btu/h / 9:9000Btu/h / 12:12000Btu/h / 14:14000Btu/h models
 •The above is the value for connecting with Wall Mounted [KG] type.
 •2 or more indoor units should be connected.
 •Heating capacity is based on 20°CDB (indoor temperature), 7°CDB/6°CWB (outdoor temperature).
 •Pipe Length: 5 m, Height difference: 0 m (Outdoor unit to Indoor unit)
 •The Total ability of connected indoor unit is up to 26000Btu from 14000Btu.



2 Rooms Multi cooling

AOYG14LAC2	Combination of Indoor Unit		COOLING OPERATION							
			Cooling Capacity			Input Power (min-max)	EER	Seasonal Data		
			Room 1 kW	Room 2 kW	Total Capacity (min-max) kW			Pdesign kW	SEER	Energy efficiency class
2 Room	7	7	2.00	2.00	4.00 (1.4-4.4)	1.09 (0.35-1.40)	3.67	4.0	6.7	A++
	7	9	1.95	2.05	4.00 (1.4-4.4)	1.09 (0.35-1.40)	3.67	4.0	6.6	A++
	7	12	1.65	2.35	4.00 (1.4-4.6)	1.05 (0.35-1.47)	3.81	4.0	6.5	A++
	9	9	2.00	2.00	4.00 (1.4-4.5)	1.09 (0.35-1.43)	3.67	4.0	6.6	A++
	9	12	1.70	2.30	4.00 (1.4-4.7)	1.05 (0.35-1.47)	3.81	4.0	6.5	A++

Note: •7:7000Btu/h / 9:9000Btu/h / 12:12000Btu/h models
 •The above is the value for connecting with Wall Mounted type.
 •2 or more indoor units should be connected.
 •Cooling capacity is based on 27°CDB/19°CWB (indoor temperature), 35°CDB (outdoor temperature).
 •Pipe Length: 5 m, Height difference: 0 m (Outdoor unit to Indoor unit)
 •The Total ability of connected indoor unit is up to 21000Btu from 14000Btu.

AOYG18LAC2	Combination of Indoor Unit		COOLING OPERATION							
			Cooling Capacity			Input Power (min-max)	EER	Seasonal Data		
			Room 1 kW	Room 2 kW	Total Capacity (min-max) kW			Pdesign kW	SEER	Energy efficiency class
2 Room	7	7	2.10	2.10	4.20 (1.7-5.2)	1.24 (0.35-1.68)	3.39	4.2	7.0	A++
	7	9	2.10	2.50	4.60 (1.7-5.3)	1.26 (0.35-1.79)	3.65	4.6	6.8	A++
	7	12	1.90	3.10	5.00 (1.7-5.6)	1.55 (0.35-1.95)	3.23	5.0	6.5	A++
	7	14	1.80	3.20	5.00 (1.8-5.7)	1.55 (0.40-1.99)	3.23	5.0	6.5	A++
	9	9	2.50	2.50	5.00 (1.7-5.6)	1.56 (0.35-1.95)	3.21	5.0	6.6	A++
	9	12	2.10	2.90	5.00 (1.7-5.7)	1.55 (0.35-1.95)	3.23	5.0	6.5	A++
	9	14	2.00	3.00	5.00 (1.8-5.8)	1.55 (0.40-1.99)	3.23	5.0	6.4	A++
	12	12	2.50	2.50	5.00 (1.7-5.8)	1.56 (0.35-1.99)	3.21	5.0	6.4	A++

Note: •7:7000Btu/h / 9:9000Btu/h / 12:12000Btu/h / 14:14000Btu/h models
 •The above is the value for connecting with Wall Mounted type.
 •2 or more indoor units should be connected.
 •Cooling capacity is based on 27°CDB/19°CWB (indoor temperature), 35°CDB (outdoor temperature).
 •Pipe Length: 5 m, Height difference: 0 m (Outdoor unit to Indoor unit)
 •The Total ability of connected indoor unit is up to 24000Btu from 14000Btu.
 •Where "14" means "wall mounted type" only models. Other types of indoor units cannot be connected.

2 Rooms Multi heating

AOYG14LAC2	Combination of Indoor Unit		HEATING OPERATION							
			Heating Capacity			Input Power (min-max)	COP	Seasonal Data		
			Room 1 kW	Room 2 kW	Total Capacity (min-max) kW			Pdesign kW	SCOP	Energy efficiency class
2 Room	7	7	2.20	2.20	4.40 (1.1-5.4)	1.03 (0.25-1.78)	4.27	3.8	4.1	A+
	7	9	2.15	2.25	4.40 (1.1-5.4)	1.03 (0.25-1.78)	4.27	3.8	4.1	A+
	7	12	1.95	2.45	4.40 (1.1-5.5)	1.02 (0.25-1.76)	4.31	3.8	4.0	A+
	9	9	2.20	2.20	4.40 (1.1-5.4)	1.03 (0.25-1.78)	4.27	3.8	4.0	A+
	9	12	2.00	2.40	4.40 (1.1-5.5)	1.02 (0.25-1.76)	4.31	3.8	4.0	A+

Note: •7:7000Btu/h / 9:9000Btu/h / 12:12000Btu/h models
 •The above is the value for connecting with Wall Mounted type.
 •2 or more indoor units should be connected.
 •Heating capacity is based on 20°CDB (indoor temperature), 7°CDB/6°CWB (outdoor temperature).
 •Pipe Length: 5 m, Height difference: 0 m (Outdoor unit to Indoor unit)
 •The Total ability of connected indoor unit is up to 21000Btu from 14000Btu.

AOYG18LAC2	Combination of Indoor Unit		HEATING OPERATION							
			Heating Capacity			Input Power (min-max)	COP	Seasonal Data		
			Room 1 kW	Room 2 kW	Total Capacity (min-max) kW			Pdesign kW	SCOP	Energy efficiency class
2 Room	7	7	2.70	2.70	5.40 (1.8-6.0)	1.24 (0.50-1.61)	4.37	3.8	4.1	A+
	7	9	2.50	3.00	5.50 (1.8-6.0)	1.36 (0.50-1.87)	4.04	4.0	4.1	A+
	7	12	2.30	3.30	5.60 (1.8-6.1)	1.38 (0.50-1.88)	4.06	4.2	4.0	A+
	7	14	2.25	3.35	5.60 (1.9-6.2)	1.35 (0.55-1.86)	4.15	4.2	4.0	A+
	9	9	2.80	2.80	5.60 (1.8-6.1)	1.41 (0.50-1.90)	3.97	4.2	4.1	A+
	9	12	2.45	3.15	5.60 (1.8-6.2)	1.38 (0.50-1.88)	4.07	4.2	4.0	A+
	9	14	2.35	3.25	5.60 (1.9-6.3)	1.35 (0.55-1.86)	4.15	4.2	4.0	A+
	12	12	2.80	2.80	5.60 (1.8-6.3)	1.34 (0.50-1.84)	4.18	4.2	4.0	A+

Note: •7:7000Btu/h / 9:9000Btu/h / 12:12000Btu/h / 14:14000Btu/h models
 •The above is the value for connecting with Wall Mounted type.
 •2 or more indoor units should be connected.
 •Heating capacity is based on 20°CDB (indoor temperature), 7°CDB/6°CWB (outdoor temperature).
 •Pipe Length: 5 m, Height difference: 0 m (Outdoor unit to Indoor unit)
 •The Total ability of connected indoor unit is up to 24000Btu from 14000Btu.
 •Where "14" means "wall mounted type" only models. Other types of indoor units cannot be connected.

MULTI SPLIT

3 Rooms Multi Combination Table-Cooling/Heating

3 Rooms Multi cooling

AOYG18LAT3	Combination of Indoor Unit			COOLING OPERATION							Seasonal Data		
				Cooling Capacity				Input Power (min-max)		EER			
				Room 1 kW	Room 2 kW	Room 3 kW	Total Capacity (min-max) kW	kW			Pdesign kW	SEER	Energy efficiency
2 Room	7	7	-	2.30	2.30	-	4.60 (1.8-5.0)	1.22 (0.50-1.43)		3.77	4.6	6.3	A++
	7	9	-	2.30	2.70	-	5.00 (1.8-5.7)	1.35 (0.50-1.81)		3.70	5.0	6.2	A++
	7	12	-	1.98	3.02	-	5.00 (1.8-6.1)	1.34 (0.50-2.06)		3.73	5.0	6.2	A++
	7	14	-	1.88	3.42	-	5.30 (1.8-6.6)	1.34 (0.50-2.06)		3.96	5.3	6.1	A++
	9	9	-	2.50	2.50	-	5.00 (1.8-6.2)	1.35 (0.50-2.06)		3.70	5.0	6.2	A++
	9	12	-	2.18	2.82	-	5.00 (1.8-6.3)	1.35 (0.50-2.06)		3.70	5.0	6.2	A++
	9	14	-	2.07	3.23	-	5.30 (1.8-6.7)	1.35 (0.50-2.06)		3.93	5.3	6.1	A++
	12	12	-	2.55	2.55	-	5.10 (1.8-6.3)	1.35 (0.50-2.06)		3.78	5.1	6.1	A++
3 Room	7	7	7	1.80	1.80	1.80	5.40 (1.8-6.8)	1.35 (0.50-2.06)		4.00	5.4	6.9	A++
	7	7	9	1.70	1.70	2.00	5.40 (1.8-6.8)	1.35 (0.50-2.06)		4.00	5.4	6.9	A++
	7	7	12	1.53	1.53	2.33	5.40 (1.8-6.8)	1.35 (0.50-2.06)		4.00	5.4	6.7	A++
	7	7	14	1.41	1.41	2.58	5.40 (2.0-6.8)	1.35 (0.60-2.06)		4.00	5.4	6.7	A++
	7	9	9	1.61	1.89	1.89	5.40 (1.8-6.8)	1.35 (0.50-2.06)		4.00	5.4	6.8	A++
	7	9	12	1.46	1.72	2.22	5.40 (1.8-6.8)	1.35 (0.50-2.06)		4.00	5.4	6.7	A++
	7	9	14	1.35	1.58	2.47	5.40 (2.0-6.8)	1.35 (0.60-2.06)		4.00	5.4	6.7	A++
	9	9	9	1.80	1.80	1.80	5.40 (1.8-6.8)	1.35 (0.50-2.06)		4.00	5.4	6.8	A++
	9	9	12	1.64	1.64	2.12	5.40 (1.8-6.8)	1.35 (0.50-2.06)		4.00	5.4	6.7	A++

AOYG24LAT3	Combination of Indoor Unit			COOLING OPERATION							Seasonal Data		
				Cooling Capacity				Input Power (min-max)		EER			
				Room 1 kW	Room 2 kW	Room 3 kW	Total Capacity (min-max) kW	kW			Pdesign kW	SEER	Energy efficiency
2 Room	7	7	-	2.30	2.30	-	4.60 (1.8-5.0)	1.20 (0.50-1.40)		3.83	4.6	6.3	A++
	7	9	-	2.30	2.70	-	5.00 (1.8-5.7)	1.36 (0.50-1.78)		3.68	5.0	6.2	A++
	7	12	-	2.38	3.42	-	5.80 (1.8-6.1)	1.70 (0.50-1.97)		3.41	5.8	6.1	A++
	7	14	-	2.37	4.13	-	6.50 (1.8-7.2)	1.91 (0.50-2.46)		3.40	6.5	6.0	A+
	7	18	-	2.08	4.52	-	6.60 (1.8-7.8)	1.91 (0.50-2.87)		3.46	6.6	5.9	A+
	9	9	-	2.75	2.75	-	5.50 (1.8-6.2)	1.55 (0.50-2.02)		3.55	5.5	6.1	A++
	9	12	-	2.79	3.41	-	6.20 (1.8-6.8)	1.90 (0.50-2.45)		3.26	6.2	5.9	A+
	9	14	-	2.66	3.94	-	6.60 (1.8-7.7)	1.91 (0.50-2.77)		3.46	6.6	6.0	A+
	9	18	-	2.35	4.35	-	6.70 (1.8-7.9)	1.91 (0.50-2.87)		3.51	6.7	5.9	A+
	12	12	-	3.15	3.15	-	6.30 (1.8-7.2)	1.90 (0.50-2.74)		3.32	6.3	5.9	A+
	12	14	-	3.03	3.67	-	6.70 (1.8-7.8)	1.91 (0.50-2.87)		3.51	6.7	5.9	A+
	12	18	-	2.66	4.04	-	6.70 (1.8-7.9)	1.92 (0.50-2.87)		3.49	6.7	5.8	A+
3 Room	7	7	7	2.23	2.23	2.23	6.70 (1.8-7.4)	1.89 (0.50-2.37)		3.54	6.7	6.4	A++
	7	7	9	2.14	2.14	2.52	6.80 (1.8-7.8)	1.94 (0.60-2.87)		3.51	6.8	6.4	A++
	7	7	12	1.98	1.98	2.84	6.80 (1.8-8.1)	1.93 (0.50-2.87)		3.52	6.8	6.3	A++
	7	7	14	1.82	1.82	3.16	6.80 (2.0-8.4)	1.94 (0.60-2.87)		3.51	6.8	6.2	A++
	7	7	18	1.63	1.63	3.54	6.80 (2.0-8.5)	1.94 (0.60-2.87)		3.51	6.8	6.1	A++
	7	9	9	2.03	2.38	2.38	6.80 (1.8-8.2)	1.93 (0.50-2.87)		3.52	6.8	6.4	A++
	7	9	12	1.88	2.21	2.70	6.80 (1.8-8.2)	1.93 (0.50-2.87)		3.52	6.8	6.2	A++
	7	9	14	1.74	2.04	3.02	6.80 (2.0-8.4)	1.94 (0.60-2.87)		3.51	6.8	6.2	A++
	7	9	18	1.56	1.84	3.40	6.80 (2.0-8.5)	1.94 (0.60-2.87)		3.51	6.8	6.1	A++
	7	12	12	1.76	2.52	2.52	6.80 (1.8-8.2)	1.94 (0.50-2.87)		3.51	6.8	6.2	A++
	7	12	14	1.63	2.34	2.83	6.80 (2.0-8.5)	1.94 (0.60-2.87)		3.51	6.8	6.2	A++
	9	9	9	2.27	2.27	2.27	6.80 (1.8-8.2)	1.94 (0.50-2.87)		3.51	6.8	6.4	A++
	9	9	12	2.11	2.11	2.58	6.80 (1.8-8.3)	1.94 (0.50-2.87)		3.51	6.8	6.2	A++
	9	9	14	1.95	1.95	2.89	6.80 (2.0-8.5)	1.94 (0.60-2.87)		3.51	6.8	6.2	A++
	9	9	18*	1.77	1.77	3.27	6.80 (2.0-8.5)	1.94 (0.60-2.87)		3.51	6.8	6.1	A++
	9	12	12	1.97	2.41	2.41	6.80 (1.8-8.3)	1.94 (0.50-2.87)		3.51	6.8	6.2	A++
9	12	14	1.84	2.24	2.72	6.80 (2.0-8.5)	1.94 (0.60-2.87)		3.51	6.8	6.2	A++	
12	12	12	2.27	2.27	2.27	6.80 (1.8-8.3)	1.94 (0.50-2.87)		3.51	6.8	6.1	A++	

Note: *7:7000Btu/h / 9:9000Btu/h / 12:12000Btu/h / 14:14000Btu/h / 18:18000Btu/h models
 •The above is the value for connecting with Wall Mounted type.
 •2 or more indoor units should be connected.
 •Cooling capacity is based on 27°CDB/19°CWB (indoor temperature), 35°CDB (outdoor temperature).
 •Pipe Length: 5 m. Height difference: 0 m (Outdoor unit to Indoor unit)
 •The total ability of connectable indoor units is up to 36000Btu from 14000Btu.
 *1: When ASYG18L is connected, connect at least 1 wall mounted type of 9000Btu.

3 Rooms Multi heating

AOYG18LAT3	Combination of Indoor Unit			HEATING OPERATION							Seasonal Data		
				Heating Capacity				Input Power (min-max)	COP	Pdesign	SCOP	Energy efficiency	
				Room 1	Room 2	Room 3	Total Capacity (min-max)						kW
2 Room	7	7	-	2.70	2.70	-	5.40 (2.0-6.1)	1.59 (0.52-1.93)	3.40	4.0	4.1	A+	
	7	9	-	2.75	3.25	-	6.00 (2.0-6.4)	1.87 (0.52-2.06)	3.21	4.0	4.1	A+	
	7	12	-	2.59	3.71	-	6.30 (2.0-6.5)	1.98 (0.52-2.06)	3.18	4.0	4.1	A+	
	7	14	-	2.51	4.29	-	6.80 (2.0-7.1)	1.92 (0.50-2.06)	3.54	4.0	4.1	A+	
	9	9	-	3.15	3.15	-	6.30 (2.0-6.5)	1.98 (0.52-2.06)	3.18	4.0	4.1	A+	
	9	12	-	2.89	3.51	-	6.40 (2.0-6.6)	1.99 (0.52-2.06)	3.22	4.0	4.1	A+	
	9	14	-	2.77	4.03	-	6.80 (2.0-7.2)	1.91 (0.50-2.06)	3.56	4.0	4.1	A+	
	12	12	-	3.20	3.20	-	6.40 (2.0-6.6)	1.98 (0.52-2.06)	3.23	4.0	4.1	A+	
3 Room	7	7	7	2.27	2.27	2.27	6.80 (2.0-7.7)	1.62 (0.50-2.06)	4.20	5.0	4.3	A+	
	7	7	9	2.14	2.14	2.52	6.80 (2.0-7.8)	1.62 (0.50-2.06)	4.20	5.0	4.3	A+	
	7	7	12	1.98	1.98	2.83	6.80 (2.0-7.8)	1.59 (0.50-2.06)	4.28	5.0	4.3	A+	
	7	7	14	1.83	1.83	3.14	6.80 (2.0-8.0)	1.61 (0.50-2.06)	4.22	5.0	4.3	A+	
	7	9	9	2.03	2.39	2.39	6.80 (2.0-7.8)	1.60 (0.50-2.06)	4.25	5.0	4.3	A+	
	7	9	12	1.89	2.22	2.69	6.80 (2.0-7.9)	1.59 (0.50-2.06)	4.28	5.0	4.3	A+	
	7	9	14	1.75	2.06	2.99	6.80 (2.0-8.0)	1.60 (0.50-2.06)	4.25	5.0	4.3	A+	
	9	9	9	2.27	2.27	2.27	6.80 (2.0-7.9)	1.59 (0.50-2.06)	4.28	5.0	4.3	A+	
	9	9	12	2.12	2.12	2.57	6.80 (2.0-7.9)	1.59 (0.50-2.06)	4.28	5.0	4.3	A+	

AOYG24LAT3	Combination of Indoor Unit			HEATING OPERATION							Seasonal Data		
				Heating Capacity				Input Power (min-max)	COP	Pdesign	SCOP	Energy efficiency	
				Room 1	Room 2	Room 3	Total Capacity (min-max)						kW
2 Room	7	7	-	2.75	2.75	-	5.50 (2.0-6.1)	1.55 (0.52-1.93)	3.55	4.0	4.1	A+	
	7	9	-	2.80	3.30	-	6.10 (2.0-7.0)	1.82 (0.52-2.52)	3.35	4.0	4.1	A+	
	7	12	-	2.88	4.12	-	7.00 (2.0-7.3)	2.31 (0.52-2.66)	3.03	4.0	4.1	A+	
	7	14	-	2.80	4.80	-	7.60 (2.0-8.3)	2.28 (0.50-2.87)	3.33	4.0	4.1	A+	
	7	18	-	2.51	5.39	-	7.90 (2.0-8.3)	2.34 (0.50-2.87)	3.38	4.0	4.1	A+	
	9	9	-	3.30	3.30	-	6.60 (2.0-7.4)	2.04 (0.52-2.68)	3.24	4.0	4.1	A+	
	9	12	-	3.30	4.00	-	7.30 (2.0-7.7)	2.43 (0.52-2.87)	3.00	4.0	4.1	A+	
	9	14	-	3.22	4.68	-	7.90 (2.0-8.3)	2.38 (0.50-2.87)	3.32	4.0	4.1	A+	
	9	18	-	2.84	5.16	-	8.00 (2.0-8.5)	2.32 (0.50-2.87)	3.45	4.0	4.1	A+	
	12	12	-	3.80	3.80	-	7.60 (2.0-7.8)	2.54 (0.52-2.87)	2.99	4.0	4.1	A+	
	12	14	-	3.59	4.31	-	7.90 (2.0-8.4)	2.37 (0.50-2.87)	3.33	4.0	4.1	A+	
	12	18	-	3.20	4.80	-	8.00 (2.0-8.6)	2.31 (0.50-2.87)	3.46	4.0	4.1	A+	
3 Room	7	7	7	2.60	2.60	2.60	7.80 (2.0-8.6)	1.94 (0.50-2.68)	4.02	5.0	4.3	A+	
	7	7	9	2.52	2.52	2.96	8.00 (2.0-8.8)	2.00 (0.50-2.87)	4.00	5.2	4.2	A+	
	7	7	12	2.34	2.34	3.32	8.00 (2.0-8.9)	1.99 (0.50-2.80)	4.02	5.2	4.2	A+	
	7	7	14	2.16	2.16	3.68	8.00 (2.0-9.2)	1.91 (0.50-2.72)	4.19	5.2	4.2	A+	
	7	7	18	1.94	1.94	4.12	8.00 (2.0-9.2)	1.89 (0.50-2.70)	4.23	5.2	4.2	A+	
	7	9	9	2.38	2.81	2.81	8.00 (2.0-9.0)	1.99 (0.50-2.87)	4.02	5.2	4.2	A+	
	7	9	12	2.23	2.62	3.15	8.00 (2.0-9.1)	1.98 (0.50-2.87)	4.04	5.2	4.2	A+	
	7	9	14	2.06	2.42	3.52	8.00 (2.0-9.2)	1.91 (0.50-2.72)	4.19	5.2	4.2	A+	
	7	9	18	1.85	2.18	3.97	8.00 (2.0-9.2)	1.89 (0.50-2.69)	4.23	5.2	4.2	A+	
	7	12	12	2.08	2.96	2.96	8.00 (2.0-9.1)	1.97 (0.50-2.87)	4.06	5.2	4.2	A+	
	7	12	14	1.93	2.76	3.31	8.00 (2.0-9.2)	1.90 (0.50-2.70)	4.21	5.2	4.2	A+	
	9	9	9	2.67	2.67	2.67	8.00 (2.0-9.1)	1.98 (0.50-2.87)	4.04	5.2	4.2	A+	
	9	9	12	2.49	2.49	3.02	8.00 (2.0-9.2)	1.97 (0.50-2.87)	4.06	5.2	4.2	A+	
	9	9	14	2.32	2.32	3.37	8.00 (2.0-9.2)	1.89 (0.50-2.70)	4.23	5.2	4.2	A+	
	9	9	18*	2.10	2.10	3.81	8.00 (2.0-9.2)	1.87 (0.50-2.68)	4.28	5.2	4.2	A+	
	9	12	12	2.34	2.83	2.83	8.00 (2.0-9.2)	1.96 (0.50-2.80)	4.08	5.2	4.2	A+	
9	12	14	2.18	2.64	3.17	8.00 (2.0-9.2)	1.89 (0.50-2.69)	4.23	5.2	4.2	A+		
12	12	12	2.67	2.67	2.67	8.00 (2.0-9.2)	1.95 (0.50-2.78)	4.10	5.2	4.2	A+		

Note: •7:7000Btu/h / 9:9000Btu/h / 12:12000Btu/h / 14:14000Btu/h / 18:18000Btu/h models
 •The above is the value for connecting with Wall Mounted type.
 •2 or more indoor units should be connected.
 •Heating capacity is based on 20°CDB (indoor temperature), 7°CDB/6°CWB (outdoor temperature).
 •Pipe Length: 5 m, Height difference: 0 m (Outdoor unit to Indoor unit)
 •The Total ability of connected indoor unit is up to 36000Btu from 14000Btu.
 *1: When ASYG18L is connected, connect at least 1 wall mounted type for 9000Btu.

5 Rooms Multi cooling

AOYG36LBLA5	Combination of Indoor Unit					COOLING OPERATION									
						Cooling Capacity					Input Power (min-max)	EER	Seasonal Data		
						Room 1	Room 2	Room 3	Room 4	Room 5			Total Capacity (min-max)	Pdesign	SEER
kW	kW	kW	kW	kW	kW	kW	kW	kW	kW	kW	kW	kW	kW		
7	7	7	7	7	2.00	2.00	2.00	2.00	2.00	10.0 (3.5-12.5)	2.44 (0.8-3.88)	4.10	10.0	7.0	A++
7	7	7	7	9	1.89	1.89	1.89	1.89	2.44	10.0 (3.5-12.5)	2.44 (0.8-3.88)	4.10	10.0	7.0	A++
7	7	7	7	12	1.75	1.75	1.75	1.75	3.00	10.0 (3.5-12.5)	2.43 (0.8-3.88)	4.11	10.0	7.0	A++
7	7	7	7	14	1.67	1.67	1.67	1.67	3.32	10.0 (3.5-12.5)	2.42 (0.8-3.88)	4.13	10.0	7.0	A++
7	7	7	7	18	1.52	1.52	1.52	1.52	3.92	10.0 (3.5-12.5)	2.41 (0.8-3.88)	4.15	10.0	6.9	A++
7	7	7	7	24	1.35	1.35	1.35	1.35	4.60	10.0 (3.5-12.5)	2.39 (0.8-3.88)	4.19	10.0	6.9	A++
7	7	7	9	9	1.79	1.79	1.79	2.31	2.31	10.0 (3.5-12.5)	2.43 (0.8-3.88)	4.11	10.0	7.0	A++
7	7	7	9	12	1.67	1.67	1.67	2.14	2.85	10.0 (3.5-12.5)	2.42 (0.8-3.88)	4.13	10.0	7.0	A++
7	7	7	9	14	1.59	1.59	1.59	2.05	3.18	10.0 (3.5-12.5)	2.42 (0.8-3.88)	4.14	10.0	7.0	A++
7	7	7	9	18	1.46	1.46	1.46	1.88	3.74	10.0 (3.5-12.5)	2.40 (0.8-3.88)	4.17	10.0	6.9	A++
7	7	7	9	24	1.30	1.30	1.30	1.67	4.43	10.0 (3.5-12.5)	2.38 (0.8-3.88)	4.21	10.0	6.9	A++
7	7	7	12	12	1.56	1.56	1.56	2.66	2.66	10.0 (3.5-12.5)	2.41 (0.8-3.88)	4.15	10.0	7.0	A++
7	7	7	12	14	1.49	1.49	1.49	2.55	2.98	10.0 (3.5-12.5)	2.40 (0.8-3.88)	4.16	10.0	6.9	A++
7	7	7	12	18	1.37	1.37	1.37	2.35	3.54	10.0 (3.5-12.5)	2.39 (0.8-3.88)	4.19	10.0	6.9	A++
7	7	7	14	14	1.43	1.43	1.43	2.86	2.86	10.0 (3.5-12.5)	2.40 (0.8-3.88)	4.17	10.0	6.9	A++
7	7	7	14	18	1.32	1.32	1.32	2.64	3.40	10.0 (3.5-12.5)	2.38 (0.8-3.88)	4.20	10.0	6.9	A++
7	7	9	9	9	1.70	1.70	2.20	2.20	2.20	10.0 (3.5-12.5)	2.43 (0.8-3.88)	4.12	10.0	7.0	A++
7	7	9	9	12	1.59	1.59	2.05	2.05	2.72	10.0 (3.5-12.5)	2.42 (0.8-3.88)	4.14	10.0	7.0	A++
7	7	9	9	14	1.52	1.52	1.96	1.96	3.04	10.0 (3.5-12.5)	2.41 (0.8-3.88)	4.15	10.0	6.9	A++
7	7	9	9	18	1.40	1.40	1.80	1.80	3.60	10.0 (3.5-12.5)	2.39 (0.8-3.88)	4.18	10.0	6.9	A++
7	7	9	12	12	1.49	1.49	1.92	2.55	2.55	10.0 (3.5-12.5)	2.40 (0.8-3.88)	4.16	10.0	6.9	A++
7	7	9	12	14	1.43	1.43	1.84	2.45	2.85	10.0 (3.5-12.5)	2.40 (0.8-3.88)	4.17	10.0	6.9	A++
7	7	9	12	18	1.32	1.32	1.70	2.26	3.40	10.0 (3.5-12.5)	2.38 (0.8-3.88)	4.20	10.0	6.9	A++
7	7	9	14	14	1.37	1.37	1.76	2.75	2.75	10.0 (3.5-12.5)	2.39 (0.8-3.88)	4.19	10.0	6.9	A++
7	7	12	12	12	1.40	1.40	2.40	2.40	2.40	10.0 (3.5-12.5)	2.39 (0.8-3.88)	4.18	10.0	6.9	A++
7	7	12	12	14	1.35	1.35	2.31	2.31	2.68	10.0 (3.5-12.5)	2.39 (0.8-3.88)	4.19	10.0	6.9	A++
7	7	12	14	14	1.30	1.30	2.22	2.59	2.59	10.0 (3.5-12.5)	2.38 (0.8-3.88)	4.21	10.0	6.9	A++
7	9	9	9	9	1.64	2.09	2.09	2.09	2.09	10.0 (3.5-12.5)	2.42 (0.8-3.88)	4.13	10.0	7.0	A++
7	9	9	9	12	1.52	1.96	1.96	1.96	2.60	10.0 (3.5-12.5)	2.41 (0.8-3.88)	4.15	10.0	6.9	A++
7	9	9	9	14	1.46	1.88	1.88	1.88	2.90	10.0 (3.5-12.5)	2.40 (0.8-3.88)	4.17	10.0	6.9	A++
7	9	9	9	18	1.35	1.73	1.73	1.73	3.46	10.0 (3.5-12.5)	2.39 (0.8-3.88)	4.19	10.0	6.9	A++
7	9	9	12	12	1.42	1.84	1.84	2.45	2.45	10.0 (3.5-12.5)	2.40 (0.8-3.88)	4.17	10.0	6.9	A++
7	9	9	12	14	1.37	1.76	1.76	2.35	2.76	10.0 (3.5-12.5)	2.39 (0.8-3.88)	4.19	10.0	6.9	A++
7	9	9	14	14	1.32	1.70	1.70	2.64	2.64	10.0 (3.5-12.5)	2.38 (0.8-3.88)	4.20	10.0	6.9	A++
7	9	12	12	14	1.34	1.73	2.31	2.31	2.31	10.0 (3.5-12.5)	2.39 (0.8-3.88)	4.19	10.0	6.9	A++
7	9	12	14	14	1.30	1.67	2.22	2.22	2.59	10.0 (3.5-12.5)	2.38 (0.8-3.88)	4.21	10.0	6.9	A++
9	9	9	9	9	2.00	2.00	2.00	2.00	2.00	10.0 (3.5-12.5)	2.41 (0.8-3.88)	4.15	10.0	7.0	A++
9	9	9	9	12	1.88	1.88	1.88	1.88	2.48	10.0 (3.5-12.5)	2.40 (0.8-3.88)	4.17	10.0	6.9	A++
9	9	9	9	14	1.80	1.80	1.80	1.80	2.80	10.0 (3.5-12.5)	2.39 (0.8-3.88)	4.18	10.0	6.9	A++
9	9	9	9	18	1.67	1.67	1.67	1.67	3.32	10.0 (3.5-12.5)	2.38 (0.8-3.88)	4.21	10.0	6.9	A++
9	9	9	12	12	1.76	1.76	1.76	2.36	2.36	10.0 (3.5-12.5)	2.39 (0.8-3.88)	4.19	10.0	6.9	A++
9	9	9	12	14	1.70	1.70	1.70	2.26	2.64	10.0 (3.5-12.5)	2.38 (0.8-3.88)	4.20	10.0	6.9	A++
9	9	12	12	12	1.67	1.67	2.22	2.22	2.22	10.0 (3.5-12.5)	2.38 (0.8-3.88)	4.21	10.0	6.9	A++

Note: •7:7000Btu/h / 9:9000Btu/h / 12:12000Btu/h / 14:14000Btu/h / 18:18000Btu/h / 24:24000Btu/h models
 •The above is the value for connecting with Wall Mounted type.
 •2 or more indoor units should be connected.
 •Cooling capacity is based on 27°CDB/19°CWB (indoor temperature), 35°CDB (outdoor temperature).
 •Pipe Length: 5 m, Height difference: 0 m (Outdoor unit to Indoor unit)
 •The Total ability of connected indoor unit is up to 54000Btu from 27000Btu.

5 Rooms Multi heating

AOYG36LBLA5	Combination of Indoor Unit					HEATING OPERATION							Seasonal Data			
						Heating Capacity					Input Power (min-max)	COP	Pdesign	SCOP	Energy efficiency	
						Room 1	Room 2	Room 3	Room 4	Room 5						Total Capacity (min-max)
7	7	7	7	7	7	2.40	2.40	2.40	2.40	2.40	12.0 (3.5-14.0)	2.79 (0.7-3.82)	4.30	9.0	4.4	A+
7	7	7	7	9	9	2.27	2.27	2.27	2.27	2.92	12.0 (3.5-14.0)	2.79 (0.7-3.82)	4.30	9.0	4.4	A+
7	7	7	7	12	12	2.10	2.10	2.10	2.10	3.60	12.0 (3.5-14.0)	2.78 (0.7-3.82)	4.31	9.0	4.4	A+
7	7	7	7	14	14	2.00	2.00	2.00	2.00	4.00	12.0 (3.5-14.0)	2.78 (0.7-3.82)	4.32	9.0	4.4	A+
7	7	7	7	18	18	1.83	1.83	1.83	1.83	4.68	12.0 (3.5-14.0)	2.77 (0.7-3.82)	4.33	9.0	4.4	A+
7	7	7	7	24	24	1.62	1.62	1.62	1.62	5.52	12.0 (3.5-14.0)	2.76 (0.7-3.82)	4.34	9.0	4.4	A+
7	7	7	9	9	9	2.15	2.15	2.15	2.77	2.77	12.0 (3.5-14.0)	2.78 (0.7-3.82)	4.31	9.0	4.4	A+
7	7	7	9	12	12	2.00	2.00	2.00	2.57	3.43	12.0 (3.5-14.0)	2.78 (0.7-3.82)	4.32	9.0	4.4	A+
7	7	7	9	14	14	1.91	1.91	1.91	2.45	3.82	12.0 (3.5-14.0)	2.78 (0.7-3.82)	4.32	9.0	4.4	A+
7	7	7	9	18	18	1.75	1.75	1.75	2.25	4.50	12.0 (3.5-14.0)	2.77 (0.7-3.82)	4.33	9.0	4.4	A+
7	7	7	9	24	24	1.56	1.56	1.56	2.00	5.32	12.0 (3.5-14.0)	2.76 (0.7-3.82)	4.35	9.0	4.4	A+
7	7	7	12	12	12	1.87	1.87	1.87	3.20	3.20	12.0 (3.5-14.0)	2.77 (0.7-3.82)	4.33	9.0	4.4	A+
7	7	7	12	14	14	1.79	1.79	1.79	3.06	3.57	12.0 (3.5-14.0)	2.77 (0.7-3.82)	4.33	9.0	4.4	A+
7	7	7	12	18	18	1.65	1.65	1.65	2.82	4.23	12.0 (3.5-14.0)	2.76 (0.7-3.82)	4.34	9.0	4.4	A+
7	7	7	14	14	14	1.71	1.71	1.71	3.43	3.43	12.0 (3.5-14.0)	2.76 (0.7-3.82)	4.34	9.0	4.4	A+
7	7	7	14	18	18	1.58	1.58	1.58	3.17	4.09	12.0 (3.5-14.0)	2.76 (0.7-3.82)	4.35	9.0	4.4	A+
7	7	9	9	9	9	2.05	2.05	2.63	2.63	2.63	12.0 (3.5-14.0)	2.78 (0.7-3.82)	4.31	9.0	4.4	A+
7	7	9	9	12	12	1.91	1.91	2.45	2.45	3.28	12.0 (3.5-14.0)	2.78 (0.7-3.82)	4.32	9.0	4.4	A+
7	7	9	9	14	14	1.83	1.83	2.35	2.35	3.64	12.0 (3.5-14.0)	2.77 (0.7-3.82)	4.33	9.0	4.4	A+
7	7	9	9	18	18	1.68	1.68	2.16	2.16	4.32	12.0 (3.5-14.0)	2.76 (0.7-3.82)	4.34	9.0	4.4	A+
7	7	9	12	12	12	1.79	1.79	2.30	3.06	3.06	12.0 (3.5-14.0)	2.77 (0.7-3.82)	4.33	9.0	4.4	A+
7	7	9	12	14	14	1.71	1.71	2.20	2.94	3.44	12.0 (3.5-14.0)	2.76 (0.7-3.82)	4.34	9.0	4.4	A+
7	7	9	12	18	18	1.58	1.58	2.04	2.72	4.08	12.0 (3.5-14.0)	2.76 (0.7-3.82)	4.35	9.0	4.4	A+
7	7	9	14	14	14	1.65	1.65	2.12	3.29	3.29	12.0 (3.5-14.0)	2.76 (0.7-3.82)	4.34	9.0	4.4	A+
7	7	12	12	12	12	1.68	1.68	2.88	2.88	2.88	12.0 (3.5-14.0)	2.76 (0.7-3.82)	4.34	9.0	4.4	A+
7	7	12	12	14	14	1.62	1.62	2.77	2.77	3.22	12.0 (3.5-14.0)	2.76 (0.7-3.82)	4.34	9.0	4.4	A+
7	7	12	14	14	14	1.56	1.56	2.66	3.11	3.11	12.0 (3.5-14.0)	2.76 (0.7-3.82)	4.35	9.0	4.4	A+
7	9	9	9	9	9	1.96	2.51	2.51	2.51	2.51	12.0 (3.5-14.0)	2.78 (0.7-3.82)	4.32	9.0	4.4	A+
7	9	9	9	12	12	1.83	2.35	2.35	2.35	3.12	12.0 (3.5-14.0)	2.77 (0.7-3.82)	4.33	9.0	4.4	A+
7	9	9	9	14	14	1.75	2.25	2.25	2.25	3.50	12.0 (3.5-14.0)	2.77 (0.7-3.82)	4.33	9.0	4.4	A+
7	9	9	9	18	18	1.62	2.08	2.08	2.08	4.14	12.0 (3.5-14.0)	2.76 (0.7-3.82)	4.34	9.0	4.4	A+
7	9	9	12	12	12	1.72	2.20	2.20	2.94	2.94	12.0 (3.5-14.0)	2.76 (0.7-3.82)	4.34	9.0	4.4	A+
7	9	9	12	14	14	1.65	2.12	2.12	2.82	3.29	12.0 (3.5-14.0)	2.76 (0.7-3.82)	4.34	9.0	4.4	A+
7	9	9	14	14	14	1.58	2.04	2.04	3.17	3.17	12.0 (3.5-14.0)	2.76 (0.7-3.82)	4.35	9.0	4.4	A+
7	9	12	12	12	12	1.61	2.08	2.77	2.77	2.77	12.0 (3.5-14.0)	2.76 (0.7-3.82)	4.34	9.0	4.4	A+
7	9	12	12	14	14	1.56	2.00	2.67	2.67	3.10	12.0 (3.5-14.0)	2.76 (0.7-3.82)	4.35	9.0	4.4	A+
9	9	9	9	9	9	2.40	2.40	2.40	2.40	2.40	12.0 (3.5-14.0)	2.77 (0.7-3.82)	4.33	9.0	4.4	A+
9	9	9	9	12	12	2.25	2.25	2.25	2.25	3.00	12.0 (3.5-14.0)	2.77 (0.7-3.82)	4.33	9.0	4.4	A+
9	9	9	9	14	14	2.16	2.16	2.16	2.16	3.36	12.0 (3.5-14.0)	2.76 (0.7-3.82)	4.34	9.0	4.4	A+
9	9	9	9	18	18	2.00	2.00	2.00	2.00	4.00	12.0 (3.5-14.0)	2.76 (0.7-3.82)	4.35	9.0	4.4	A+
9	9	9	12	12	12	2.12	2.12	2.12	2.82	2.82	12.0 (3.5-14.0)	2.76 (0.7-3.82)	4.34	9.0	4.4	A+
9	9	9	12	14	14	2.04	2.04	2.04	2.72	3.16	12.0 (3.5-14.0)	2.76 (0.7-3.82)	4.35	9.0	4.4	A+
9	9	12	12	12	12	2.00	2.00	2.67	2.67	2.67	12.0 (3.5-14.0)	2.76 (0.7-3.82)	4.35	9.0	4.4	A+

Note: •7:7000Btu/h / 9:9000Btu/h / 12:12000Btu/h / 14:14000Btu/h / 18:18000Btu/h / 24:24000Btu/h models
 •The above is the value for connecting with Wall Mounted type.
 •2 or more indoor units should be connected.
 •Heating capacity is based on 20°CDB (indoor temperature), 7°CDB/6°CWB (outdoor temperature).
 •Pipe Length: 5 m, Height difference: 0 m (Outdoor unit to Indoor unit)
 •The Total ability of connected indoor unit is up to 54000Btu from 27000Btu.

MULTI SPLIT

6 Rooms Multi Combination Table–Cooling/Heating

6 Rooms Multi cooling

AOYG45LBLA6	Combination of Indoor Unit						COOLING OPERATION							
							Cooling Capacity						Input Power (min-max)	EER
							Room 1	Room 2	Room 3	Room 4	Room 5	Room 6		
kW		kW		kW		kW		kW		kW				
7	7	7	7	7	7	2.00	2.00	2.00	2.00	2.00	2.00	12.0 (3.5-13.4)	3.32 (0.8-4.46)	3.61
7	7	7	7	7	9	2.00	2.00	2.00	2.00	2.00	2.50	12.5 (3.5-14.0)	3.57 (0.8-4.84)	3.50
7	7	7	7	12	7	1.86	1.86	1.86	1.86	1.86	3.20	12.5 (3.5-14.0)	3.55 (0.8-4.84)	3.52
7	7	7	7	14	7	1.79	1.79	1.79	1.79	1.79	3.55	12.5 (3.5-14.0)	3.54 (0.8-4.84)	3.53
7	7	7	7	18	7	1.65	1.65	1.65	1.65	1.65	4.25	12.5 (3.5-14.0)	3.51 (0.8-4.84)	3.56
7	7	7	7	24	7	1.48	1.48	1.48	1.48	1.48	5.10	12.5 (3.5-14.0)	3.48 (0.8-4.84)	3.59
7	7	7	7	9	9	1.90	1.90	1.90	1.90	2.45	2.45	12.5 (3.5-14.0)	3.56 (0.8-4.84)	3.51
7	7	7	7	9	12	1.79	1.79	1.79	1.79	2.29	3.05	12.5 (3.5-14.0)	3.54 (0.8-4.84)	3.53
7	7	7	7	9	14	1.72	1.72	1.72	1.72	2.20	3.42	12.5 (3.5-14.0)	3.53 (0.8-4.84)	3.54
7	7	7	7	9	18	1.59	1.59	1.59	1.59	2.05	4.09	12.5 (3.5-14.0)	3.50 (0.8-4.84)	3.57
7	7	7	7	9	24	1.43	1.43	1.43	1.43	1.85	4.93	12.5 (3.5-14.0)	3.47 (0.8-4.84)	3.60
7	7	7	7	12	12	1.68	1.68	1.68	1.68	2.89	2.89	12.5 (3.5-14.0)	3.52 (0.8-4.84)	3.55
7	7	7	7	12	14	1.62	1.62	1.62	1.62	2.78	3.24	12.5 (3.5-14.0)	3.51 (0.8-4.84)	3.56
7	7	7	7	12	18	1.51	1.51	1.51	1.51	2.59	3.87	12.5 (3.5-14.0)	3.48 (0.8-4.84)	3.59
7	7	7	7	14	14	1.56	1.56	1.56	1.56	3.13	3.13	12.5 (3.5-14.0)	3.50 (0.8-4.84)	3.57
7	7	7	7	14	18	1.46	1.46	1.46	1.46	2.92	3.74	12.5 (3.5-14.0)	3.47 (0.8-4.84)	3.60
7	7	7	9	9	9	1.82	1.82	1.82	2.34	2.34	2.34	12.5 (3.5-14.0)	3.55 (0.8-4.84)	3.52
7	7	7	9	9	12	1.72	1.72	1.72	2.21	2.21	2.92	12.5 (3.5-14.0)	3.53 (0.8-4.84)	3.54
7	7	7	9	9	14	1.65	1.65	1.65	2.12	2.12	3.31	12.5 (3.5-14.0)	3.51 (0.8-4.84)	3.56
7	7	7	9	9	18	1.54	1.54	1.54	1.97	1.97	3.94	12.5 (3.5-14.0)	3.49 (0.8-4.84)	3.58
7	7	7	9	9	12	1.62	1.62	1.62	2.08	2.78	2.78	12.5 (3.5-14.0)	3.51 (0.8-4.84)	3.56
7	7	7	9	12	14	1.56	1.56	1.56	2.01	2.68	3.13	12.5 (3.5-14.0)	3.50 (0.8-4.84)	3.57
7	7	7	9	12	18	1.46	1.46	1.46	1.88	2.50	3.74	12.5 (3.5-14.0)	3.47 (0.8-4.84)	3.60
7	7	7	9	14	14	1.51	1.51	1.51	1.93	3.02	3.02	12.5 (3.5-14.0)	3.48 (0.8-4.84)	3.59
7	7	7	12	12	12	1.54	1.54	1.54	2.63	2.63	2.63	12.5 (3.5-14.0)	3.49 (0.8-4.84)	3.58
7	7	7	12	12	14	1.48	1.48	1.48	2.54	2.54	2.98	12.5 (3.5-14.0)	3.48 (0.8-4.84)	3.59
7	7	7	12	14	14	1.43	1.43	1.43	2.47	2.87	2.87	12.5 (3.5-14.0)	3.47 (0.8-4.84)	3.60
7	7	9	9	9	9	1.75	1.75	2.25	2.25	2.25	2.25	12.5 (3.5-14.0)	3.53 (0.8-4.84)	3.54
7	7	9	9	9	12	1.65	1.65	2.12	2.12	2.12	2.84	12.5 (3.5-14.0)	3.51 (0.8-4.84)	3.56
7	7	9	9	9	14	1.59	1.59	2.05	2.05	2.05	3.17	12.5 (3.5-14.0)	3.50 (0.8-4.84)	3.57
7	7	9	9	9	18	1.48	1.48	1.91	1.91	1.91	3.81	12.5 (3.5-14.0)	3.48 (0.8-4.84)	3.59
7	7	9	9	12	12	1.56	1.56	2.01	2.01	2.68	2.68	12.5 (3.5-14.0)	3.50 (0.8-4.84)	3.57
7	7	9	9	14	14	1.51	1.51	1.94	1.94	2.59	3.01	12.5 (3.5-14.0)	3.48 (0.8-4.84)	3.59
7	7	9	9	12	18	1.41	1.41	1.81	1.81	2.42	3.64	12.5 (3.5-14.0)	3.46 (0.8-4.84)	3.61
7	7	9	9	14	14	1.46	1.46	1.88	1.88	2.91	2.91	12.5 (3.5-14.0)	3.47 (0.8-4.84)	3.60
7	7	9	12	12	12	1.48	1.48	1.92	2.54	2.54	2.54	12.5 (3.5-14.0)	3.48 (0.8-4.84)	3.59
7	7	9	12	12	14	1.43	1.43	1.85	2.46	2.46	2.87	12.5 (3.5-14.0)	3.47 (0.8-4.84)	3.60
7	7	12	12	12	12	1.41	1.41	2.42	2.42	2.42	2.42	12.5 (3.5-14.0)	3.46 (0.8-4.84)	3.61
7	9	9	9	9	9	1.70	2.16	2.16	2.16	2.16	2.16	12.5 (3.5-14.0)	3.52 (0.8-4.84)	3.55
7	9	9	9	9	12	1.59	2.05	2.05	2.05	2.05	2.71	12.5 (3.5-14.0)	3.50 (0.8-4.84)	3.57
7	9	9	9	9	14	1.54	1.97	1.97	1.97	1.97	3.08	12.5 (3.5-14.0)	3.49 (0.8-4.84)	3.58
7	9	9	9	12	12	1.50	1.94	1.94	1.94	2.59	2.59	12.5 (3.5-14.0)	3.48 (0.8-4.84)	3.59
7	9	9	9	12	14	1.46	1.88	1.88	1.88	2.50	2.90	12.5 (3.5-14.0)	3.47 (0.8-4.84)	3.60
7	9	9	12	12	12	1.44	1.84	1.84	2.46	2.46	2.46	12.5 (3.5-14.0)	3.47 (0.8-4.84)	3.60
9	9	9	9	9	9	2.08	2.08	2.08	2.08	2.08	2.08	12.5 (3.5-14.0)	3.51 (0.8-4.84)	3.56
9	9	9	9	9	12	1.97	1.97	1.97	1.97	1.97	2.65	12.5 (3.5-14.0)	3.49 (0.8-4.84)	3.58
9	9	9	9	12	12	1.88	1.88	1.88	1.88	2.49	2.49	12.5 (3.5-14.0)	3.47 (0.8-4.84)	3.60

Note: •7:7000Btu/h / 9:9000Btu/h / 12:12000Btu/h / 14:14000Btu/h / 18:18000Btu/h / 24:24000Btu/h models
 •The above is the value for connecting with Wall Mounted type.
 •2 or more indoor units should be connected.
 •Cooling capacity is based on 27°CDB/19°CWB (indoor temperature), 35°CDB (outdoor temperature).
 •Pipe Length: 5 m, Height difference: 0 m (Outdoor unit to Indoor unit)
 •The Total ability of connected indoor unit is up to 62000Btu from 34000Btu.

6 Rooms Multi Combination Table-Heating

6 Rooms Multi heating

AOYG45LBLA6	Combination of Indoor Unit						HEATING OPERATION								
							Heating Capacity						Total Capacity (min-max)	Input Power (min-max)	COP
							Room 1	Room 2	Room 3	Room 4	Room 5	Room 6			
<p>Note: *7:7000Btu/h / 9:9000Btu/h / 12:12000Btu/h / 14:14000Btu/h / 18:18000Btu/h / 24:24000Btu/h models *The above is the value for connecting with Wall Mounted type. *2 or more indoor units should be connected. *Heating capacity is based on 20°CDB (indoor temperature), 7°CDB/6°CWB (outdoor temperature). *Pipe Length: 5 m, Height difference: 0 m (Outdoor unit to Indoor unit) *The Total ability of connected indoor unit is up to 54000Btu from 27000Btu.</p>															

6 Rooms Multi heating

A0YG45LBA6	Combination of Indoor Unit						HEATING OPERATION								
							Heating Capacity						Total Capacity (min-max)	Input Power (min-max)	COP
							Room 1	Room 2	Room 3	Room 4	Room 5	Room 6			
	7	7	7	7	7	7	2.20	2.20	2.20	2.20	2.20	2.20	13.2 (3.5-15.3)	3.28 (0.7-4.20)	4.02
	7	7	7	7	7	9	2.15	2.15	2.15	2.15	2.15	2.75	13.5 (3.5-16.0)	3.37 (0.7-4.41)	4.00
	7	7	7	7	12	12	2.01	2.01	2.01	2.01	2.01	3.45	13.5 (3.5-16.0)	3.37 (0.7-4.41)	4.00
	7	7	7	7	14	14	1.93	1.93	1.93	1.93	1.93	3.85	13.5 (3.5-16.0)	3.37 (0.7-4.41)	4.00
	7	7	7	7	18	18	1.78	1.78	1.78	1.78	1.78	4.60	13.5 (3.5-16.0)	3.37 (0.7-4.41)	4.00
	7	7	7	7	24	24	1.60	1.60	1.60	1.60	1.60	5.50	13.5 (3.5-16.0)	3.37 (0.7-4.41)	4.00
	7	7	7	7	9	9	2.05	2.05	2.05	2.05	2.65	2.65	13.5 (3.5-16.0)	3.37 (0.7-4.41)	4.00
	7	7	7	7	9	12	1.93	1.93	1.93	1.93	2.48	3.30	13.5 (3.5-16.0)	3.37 (0.7-4.41)	4.00
	7	7	7	7	9	14	1.85	1.85	1.85	1.85	2.38	3.72	13.5 (3.5-16.0)	3.37 (0.7-4.41)	4.00
	7	7	7	7	9	18	1.72	1.72	1.72	1.72	2.21	4.41	13.5 (3.5-16.0)	3.37 (0.7-4.41)	4.00
	7	7	7	7	9	24	1.55	1.55	1.55	1.55	1.99	5.31	13.5 (3.5-16.0)	3.37 (0.7-4.41)	4.00
	7	7	7	7	12	12	1.82	1.82	1.82	1.82	3.11	3.11	13.5 (3.5-16.0)	3.37 (0.7-4.41)	4.00
	7	7	7	7	12	14	1.75	1.75	1.75	1.75	3.00	3.50	13.5 (3.5-16.0)	3.37 (0.7-4.41)	4.00
	7	7	7	7	12	18	1.63	1.63	1.63	1.63	2.79	4.19	13.5 (3.5-16.0)	3.37 (0.7-4.41)	4.00
	7	7	7	7	14	14	1.69	1.69	1.69	1.69	3.37	3.37	13.5 (3.5-16.0)	3.37 (0.7-4.41)	4.00
	7	7	7	7	14	18	1.58	1.58	1.58	1.58	3.15	4.03	13.5 (3.5-16.0)	3.37 (0.7-4.41)	4.00
	7	7	7	7	9	9	1.97	1.97	1.97	2.53	2.53	2.53	13.5 (3.5-16.0)	3.37 (0.7-4.41)	4.00
	7	7	7	7	9	12	1.85	1.85	1.85	2.38	2.38	3.19	13.5 (3.5-16.0)	3.37 (0.7-4.41)	4.00
	7	7	7	7	9	14	1.78	1.78	1.78	2.29	2.29	3.58	13.5 (3.5-16.0)	3.37 (0.7-4.41)	4.00
	7	7	7	7	9	18	1.66	1.66	1.66	2.13	2.13	4.26	13.5 (3.5-16.0)	3.37 (0.7-4.41)	4.00
	7	7	7	7	9	12	1.75	1.75	1.75	2.25	3.00	3.00	13.5 (3.5-16.0)	3.37 (0.7-4.41)	4.00
	7	7	7	7	9	12	1.69	1.69	1.69	2.17	2.89	3.37	13.5 (3.5-16.0)	3.37 (0.7-4.41)	4.00
	7	7	7	7	9	12	1.58	1.58	1.58	2.03	2.70	4.03	13.5 (3.5-16.0)	3.37 (0.7-4.41)	4.00
	7	7	7	7	9	14	1.63	1.63	1.63	2.09	3.26	3.26	13.5 (3.5-16.0)	3.37 (0.7-4.41)	4.00
	7	7	7	7	12	12	1.66	1.66	1.66	2.84	2.84	2.84	13.5 (3.5-16.0)	3.37 (0.7-4.41)	4.00
	7	7	7	7	12	14	1.60	1.60	1.60	2.75	2.75	3.20	13.5 (3.5-16.0)	3.37 (0.7-4.41)	4.00
	7	7	7	7	12	14	1.55	1.55	1.55	2.65	3.10	3.10	13.5 (3.5-16.0)	3.37 (0.7-4.41)	4.00
	7	7	7	7	9	9	1.89	1.89	2.43	2.43	2.43	2.43	13.5 (3.5-16.0)	3.37 (0.7-4.41)	4.00
	7	7	7	7	9	12	1.78	1.78	2.29	2.29	2.29	3.07	13.5 (3.5-16.0)	3.37 (0.7-4.41)	4.00
	7	7	7	7	9	9	1.72	1.72	2.21	2.21	2.21	3.43	13.5 (3.5-16.0)	3.37 (0.7-4.41)	4.00
	7	7	7	7	9	9	1.60	1.60	2.06	2.06	2.06	4.12	13.5 (3.5-16.0)	3.37 (0.7-4.41)	4.00
	7	7	7	7	9	12	1.69	1.69	2.17	2.17	2.89	2.89	13.5 (3.5-16.0)	3.37 (0.7-4.41)	4.00
	7	7	7	7	9	12	1.63	1.63	2.09	2.09	2.79	3.27	13.5 (3.5-16.0)	3.37 (0.7-4.41)	4.00
	7	7	7	7	9	12	1.52	1.52	1.96	1.96	2.61	3.93	13.5 (3.5-16.0)	3.37 (0.7-4.41)	4.00
	7	7	7	7	9	14	1.58	1.58	2.03	2.03	3.14	3.14	13.5 (3.5-16.0)	3.37 (0.7-4.41)	4.00
	7	7	7	7	9	12	1.60	1.60	2.05	2.75	2.75	2.75	13.5 (3.5-16.0)	3.37 (0.7-4.41)	4.00
	7	7	7	7	9	12	1.55	1.55	1.99	2.66	2.66	3.09	13.5 (3.5-16.0)	3.37 (0.7-4.41)	4.00
	7	7	7	7	12	12	1.53	1.53	2.61	2.61	2.61	2.61	13.5 (3.5-16.0)	3.37 (0.7-4.41)	4.00
	7	7	7	7	9	9	1.80	2.34	2.34	2.34	2.34	2.34	13.5 (3.5-16.0)	3.37 (0.7-4.41)	4.00
	7	7	7	7	9	9	1.72	2.21	2.21	2.21	2.21	2.94	13.5 (3.5-16.0)	3.37 (0.7-4.41)	4.00
	7	7	7	7	9	9	1.66	2.13	2.13	2.13	2.13	3.32	13.5 (3.5-16.0)	3.37 (0.7-4.41)	4.00
	7	7	7	7	9	9	1.65	2.09	2.09	2.09	2.79	2.79	13.5 (3.5-16.0)	3.37 (0.7-4.41)	4.00
	7	7	7	7	9	9	1.58	2.03	2.03	2.03	2.69	3.14	13.5 (3.5-16.0)	3.37 (0.7-4.41)	4.00
	7	7	7	7	9	12	1.54	1.99	1.99	2.66	2.66	2.66	13.5 (3.5-16.0)	3.37 (0.7-4.41)	4.00
	9	9	9	9	9	9	2.25	2.25	2.25	2.25	2.25	2.25	13.5 (3.5-16.0)	3.37 (0.7-4.41)	4.00
	9	9	9	9	9	12	2.13	2.13	2.13	2.13	2.13	2.85	13.5 (3.5-16.0)	3.37 (0.7-4.41)	4.00
	9	9	9	9	12	12	2.03	2.03	2.03	2.03	2.69	2.69	13.5 (3.5-16.0)	3.37 (0.7-4.41)	4.00

Note: •7:7000Btu/h / 9:9000Btu/h / 12:12000Btu/h / 14:14000Btu/h / 18:18000Btu/h / 24:24000Btu/h models
 •The above is the value for connecting with Wall Mounted type.
 •2 or more indoor units should be connected.
 •Heating capacity is based on 20°CDB (indoor temperature), 7°CDB/6°CWB (outdoor temperature).
 •Pipe Length: 5 m, Height difference: 0 m (Outdoor unit to Indoor unit)
 •The Total ability of connected indoor unit is up to 54000Btu from 27000Btu.

